

03B-1 | Sprockets



Z	d _e	d _p	SIMPLEX								
			d _m	D ₁	A						
8	15.2	13.06	7	4	10						
9	16.8	14.62	8	5	10						
10	18.3	16.18	9	5	10						
11	19.9	17.75	11	6	10						
12	21.5	19.32	12	6	10						
13	23.0	20.89	14	6	10						
14	24.6	22.47	15	6	10						
15	26.2	24.04	16	6	10						
16	27.8	25.63	18	8	13						
17	29.4	27.20	18	8	13						
18	30.9	28.79	18	8	13						
19	32.5	30.38	18	8	13						
20	34.1	31.96	18	8	13						
21	35.7	33.54	20	8	13						
22	37.3	35.13	20	8	13						
23	38.9	36.72	20	8	13						
24	40.5	38.30	20	8	13						
25	42.0	39.89	20	8	13						
26	43.6	41.48	25	8	15						
27	45.2	43.07	25	8	15						
28	46.8	44.65	25	8	15						
29	48.4	46.25	25	8	15						
30	50.0	47.83	25	8	15						
31	51.6	49.42	30	8	15						
32	53.2	51.01	30	8	15						
33	54.8	52.60	30	8	15						
34	56.3	54.19	30	8	15						
35	57.9	55.78	30	8	15						
36	59.5	57.37	30	8	15						
37	61.1	58.96	30	8	15						
38	62.7	60.54	30	8	15						
39	64.3	62.13	30	8	15						
40	65.9	63.73	30	8	15						
41	67.5	65.30	40	8	18						
42	69.1	66.91	40	8	18						
43	70.6	68.49	40	8	18						
44	72.2	70.09	40	8	18						
45	73.8	71.68	40	8	18						
46	75.4	73.27	40	8	18						
47	77.0	74.86	40	8	18						
48	78.6	76.45	40	8	18						
49	80.2	78.03	40	8	18						
50	81.8	79.63	40	8	18						
51	83.4	81.22	40	8	18						
52	85.0	82.81	40	8	18						
53	86.6	84.40	40	8	18						
54	88.1	85.97	40	8	18						
55	89.7	87.58	40	8	18						
56	91.3	89.17	40	8	18						
57	92.9	90.76	40	8	18						
58	94.5	92.35	50	8	20						
59	96.1	93.94	50	8	20						
60	97.7	95.53	50	8	20						
62	100.9	98.72	50	8	20						
64	104.1	101.90	50	8	20						
65	105.6	103.49	50	8	20						
66	107.2	105.08	50	8	20						
68	110.4	108.26	50	8	20						
70	113.6	111.44	50	8	20						
72	116.8	114.63	50	8	20						
75	121.6	119.40	50	8	20						
76	123.1	120.99	50	8	20						
78	126.3	124.17	70	8	30						
80	129.5	127.35	70	8	30						
85	137.5	135.31	70	8	30						
90	145.4	143.27	70	8	30						
95	153.4	151.22	70	8	30						
100	161.3	159.18	70	8	30						
110	177.2	175.09	70	8	30						
114	183.6	181.45	70	8	30						
120	193.2	191.01	70	8	30						
125	201.1	198.96	70	8	30						

SPROCKETS 5X2.5mm

For chain Acc. to DIN 8187
ISO/R 606

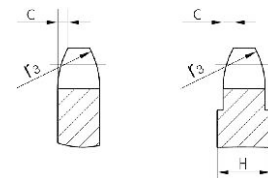
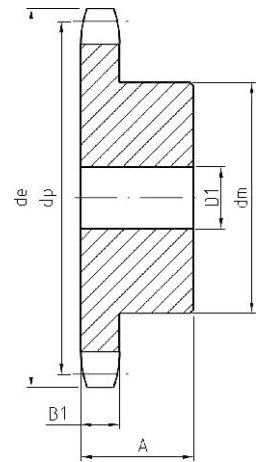

SPROCKETS mm

Tooth radius r ₃	5
Radius width C	0.6
Tooth width B ₁	2.3

CHAIN mm

Pitch	5
Internal width	2.5
Roller	3.2

H=4mm, From Z=80 the width of the plate is increased

Sprockets

03A-1 | Platewheels

Z	d _e	d _p	S
			D ₁
8	15.2	13.06	4
9	16.8	14.62	4
10	18.3	16.18	4
11	19.9	17.15	5
12	21.5	19.32	5
13	23.0	20.89	5
14	24.6	22.47	5
15	26.2	24.04	5
16	27.8	25.63	6
17	29.4	27.20	6
18	30.9	28.79	6
19	32.5	30.38	6
20	34.1	31.96	6
21	35.7	33.54	8
22	37.3	35.13	8
23	38.9	36.72	8
24	40.5	38.30	8
25	42.0	39.89	8
26	43.6	41.48	8
27	45.2	43.07	8
28	46.8	44.65	8
29	48.4	46.25	8
30	50.0	47.83	8
31	51.6	49.42	8
32	53.2	51.01	8
33	54.8	52.60	8
34	56.3	54.19	8
35	57.9	55.78	8
36	59.5	57.37	8
37	61.1	58.96	8
38	62.7	60.54	8
39	64.3	62.13	8
40	65.9	63.73	8
41	67.5	65.30	8
42	69.1	66.91	8
43	70.6	68.49	8
44	72.2	70.09	8
45	73.8	71.68	8
46	75.4	73.27	8
47	77.0	74.86	8
48	78.6	76.45	8
49	80.2	78.03	8
50	81.8	79.63	8
51	83.4	81.22	10
52	85.0	82.81	10
53	86.6	84.40	10
54	88.1	85.97	10
55	89.7	87.58	10
56	91.3	89.17	10
57	92.9	90.76	10
58	94.5	92.35	10
59	96.1	93.94	10
60	97.7	95.53	10
62	100.9	98.72	12
64	104.1	101.90	12
65	105.6	103.49	12
66	107.2	105.08	12
68	110.4	108.26	12
70	113.6	111.44	12
72	116.8	114.63	12
75	121.6	119.40	12
76	123.1	120.99	12
78	126.3	124.17	12
80	129.5	127.35	12
85	137.5	135.31	14
90	145.4	143.27	14
95	153.4	151.22	14
100	161.3	159.18	14
110	177.2	175.09	14
114	183.6	181.45	14
120	193.2	191.01	14
125	201.1	198.96	14

PLATEWHEELS 5X2.5mm

For chain Acc. to DIN 8187
ISO/R 606

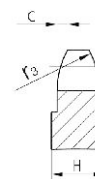
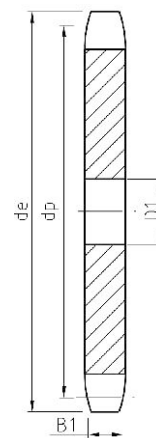

PLATEWHEELS mm

Tooth radius r ₃	5
Radius width C	0.6
Tooth width B ₁	2.3

CHAIN mm

Pitch	5
Internal width	2.5
Roller	3.2

H=4mm, From Z=51 the width of the plate is increased

Z	d _e	d _p	SIMPLEX		
			d _m	D ₁	A
8	18.0	15.67	9.8	5	10
9	19.9	17.54	11.5	5	10
10	21.7	19.42	13	6	10
11	23.6	21.30	14	6	10
12	25.4	23.18	16	6	10
13	27.3	25.05	18	8	10
14	29.2	26.96	20	8	10
15	31.0	28.86	20	8	10
16	33.0	30.76	20	8	13
17	35.0	32.65	20	8	13
18	36.9	34.55	20	8	13
19	38.8	36.44	20	8	13
20	40.7	38.34	20	8	13
21	42.6	40.25	25	8	13
22	44.5	42.16	25	8	13
23	46.4	44.06	25	8	13
24	48.3	45.96	25	8	13
25	50.2	47.87	25	8	13
26	52.1	49.76	30	8	15
27	54.0	51.67	30	8	15
28	55.9	53.58	30	8	15
29	57.8	55.50	30	8	15
30	59.8	57.42	30	8	15
31	61.7	59.31	30	8	15
32	63.6	61.21	30	8	15
33	65.5	63.11	30	8	15
34	67.4	65.02	30	8	15
35	69.3	66.93	30	8	15
36	71.2	68.84	30	8	15
37	73.1	70.75	30	8	15
38	75.0	72.66	30	8	15
39	76.9	74.57	30	8	15
40	78.9	76.47	30	8	15
41	80.8	78.38	40	8	18
42	82.7	80.28	40	8	18
43	84.7	82.20	40	8	18
44	86.6	84.10	40	8	18
45	88.5	86.01	40	8	18
46	90.4	87.92	40	8	18
47	92.3	89.83	40	8	18
48	94.2	91.74	40	8	18
49	96.1	93.64	40	8	18
50	98.0	95.55	40	8	18
51	99.9	97.46	40	8	18
52	101.8	99.37	40	8	18
53	103.7	101.27	40	8	18
54	105.6	103.17	40	8	18
55	107.6	105.08	40	8	18
56	109.5	107.00	40	8	18
57	111.4	108.93	40	8	18
58	113.3	110.82	50	8	20
59	115.2	112.71	50	8	20
60	117.1	114.62	50	8	20
62	120.9	118.45	50	8	20
64	124.7	122.27	50	8	20
65	126.6	124.18	50	8	20
66	128.5	126.09	50	8	20
68	132.4	129.91	50	8	20
70	136.2	133.73	50	8	20
72	140.0	137.55	50	8	20
75	145.7	143.28	50	8	20
76	147.6	145.19	50	8	20
78	151.5	149.01	70	8	30
80	155.3	152.82	70	8	30
85	164.8	162.37	70	8	30
90	174.4	171.92	70	8	30
95	183.9	181.47	70	8	30
100	193.5	191.01	70	8	30
110	212.6	210.11	70	8	30
114	220.2	217.75	70	8	30
120	231.7	229.20	70	8	30
125	241.2	238.75	70	8	30

SPROCKETS 6X2.8mm

For chain Acc. to DIN 8187
ISO/R 606

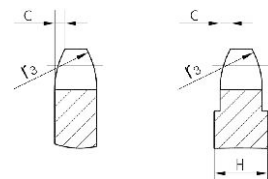
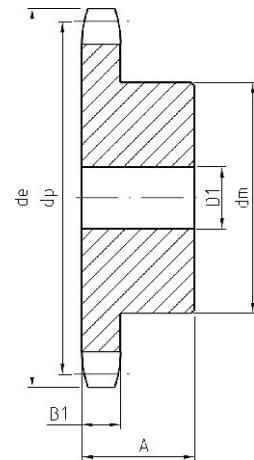

SPROCKETS mm

Tooth radius r ₃	6
Radius width C	0.7
Tooth width B ₁	2.6

CHAIN mm

Pitch	6
Internal width	2.8
Roller	4

H=4mm, From Z=66 the width of the plate is increased

04A-1 | Platewheels



Z	d _e	d _p	S	
			D ₁	
8	18.0	15.67	5	
9	19.9	17.54	5	
10	21.7	19.42	6	
11	23.6	21.30	6	
12	25.4	23.18	6	
13	27.3	25.05	8	
14	29.2	26.96	8	
15	31.0	28.86	8	
16	33.0	30.76	8	
17	35.0	32.65	8	
18	36.9	34.55	8	
19	38.8	36.44	8	
20	40.7	38.34	8	
21	42.6	40.25	8	
22	44.5	42.16	8	
23	46.4	44.06	8	
24	48.3	45.96	8	
25	50.2	47.87	8	
26	52.1	49.76	8	
27	54.0	51.67	8	
28	55.9	53.58	8	
29	57.8	55.50	8	
30	59.8	57.42	8	
31	61.7	59.31	8	
32	63.6	61.21	8	
33	65.5	63.11	8	
34	67.4	65.02	8	
35	69.3	66.93	8	
36	71.2	68.84	8	
37	73.1	70.75	8	
38	75.0	72.66	8	
39	76.9	74.57	8	
40	78.9	76.47	8	
41	80.8	78.38	10	
42	82.7	80.28	10	
43	84.7	82.19	10	
44	86.6	84.10	10	
45	88.5	86.01	10	
46	90.4	87.92	10	
47	92.3	89.83	10	
48	94.2	91.74	10	
49	96.1	93.64	10	
50	98.0	95.55	10	
51	99.9	97.46	12	
52	101.8	99.37	12	
53	103.7	101.27	12	
54	105.6	103.17	12	
55	107.6	105.08	12	
56	109.5	107.00	12	
57	111.4	108.93	12	
58	113.3	110.82	12	
59	115.2	112.71	12	
60	117.1	114.62	12	
62	120.9	118.45	14	
64	124.7	122.27	14	
65	126.6	124.18	14	
66	128.5	126.09	14	
68	132.4	129.91	14	
70	136.2	133.73	14	
72	140.0	137.55	16	
75	145.7	143.28	16	
76	147.6	145.19	16	
78	151.5	149.01	16	
80	155.3	152.82	16	
85	164.8	162.37	16	
90	174.4	171.92	16	
95	183.9	181.47	16	
100	193.5	191.01	16	
110	212.6	210.11	16	
114	220.2	217.75	16	
120	231.7	229.20	16	
125	241.2	238.75	16	

PLATEWHEELS 6X2.8mm

For chain Acc. to DIN 8187
ISO/R 606

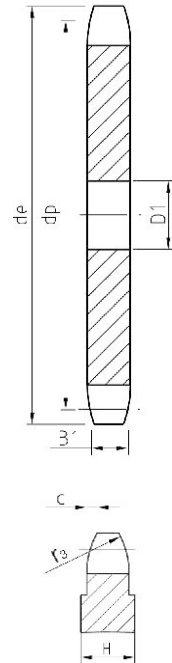

PLATEWHEELS mm

Tooth radius r _s	6
Radius width C	0.7
Tooth width B ₁	2.6

CHAIN mm

Pitch	6
Internal width	2.8
Roller	4

H=4mm, From Z=51 the width of the plate is increased

ASA25B-1-2 | Sprockets



Z	d _e	d _p	SIMPLEX							
			D _m	D ₁	A					
8	19.4	16.58	10	6	12					
9	21.4	18.56	11.5	6	12					
10	23.3	20.55	13	6	12					
11	25.3	22.54	15	8	13					
12	27.3	24.53	17	8	13					
13	29.3	26.53	17	8	13					
14	31.3	28.53	17	8	13					
15	33.3	30.53	20	8	13					
16	35.3	32.55	22	8	14					
17	37.3	34.55	22	8	14					
18	39.4	36.56	25	8	14					
19	41.4	38.58	25	8	14					
20	43.4	40.58	25	8	14					
21	45.4	42.60	30	8	14					
22	47.4	44.62	30	8	14					
23	49.4	46.63	30	8	14					
24	51.4	48.64	30	8	14					
25	53.5	50.66	30	8	14					
26	55.5	52.67	30	8	14					
27	57.5	54.69	30	8	16					
28	59.5	56.71	30	8	16					
29	61.5	58.73	30	8	16					
30	63.6	60.75	30	8	16					
31	65.6	62.76	30	8	16					
32	67.6	64.78	30	8	16					
33	69.6	66.80	30	8	16					
34	71.6	68.82	30	8	16					
35	73.6	70.84	30	8	16					
36	75.6	72.85	30	8	16					
37	77.7	74.87	30	8	16					
38	79.7	76.89	30	8	16					
39	81.7	78.91	30	8	16					
40	83.7	80.93	30	8	16					
41	85.7	82.95	40	10	18					
42	87.8	84.97	40	10	18					
43	89.8	86.98	40	10	18					
44	91.8	89.01	40	10	18					
45	93.8	91.03	40	10	18					
46	95.8	93.05	40	10	18					
47	97.9	95.07	40	10	18					
48	99.9	97.09	40	10	18					
49	101.9	99.10	40	10	18					
50	103.9	101.13	40	10	18					
51	105.9	103.14	40	10	18					
52	108.0	105.16	40	10	18					
53	110.0	107.18	40	10	18					
54	112.0	109.18	40	10	18					
55	114.0	111.23	40	10	18					
56	116.0	113.25	40	10	18					
57	118.1	115.27	40	10	18					
58	120.1	117.29	50	10	20					
59	122.1	119.31	50	10	20					
60	124.1	121.32	50	10	20					
62	128.2	125.37	50	10	20					
64	132.2	129.41	50	10	20					
65	134.2	131.43	50	10	20					
66	136.2	133.45	50	10	20					
68	140.3	137.49	50	10	20					
70	144.3	141.53	50	10	20					
72	148.4	145.58	50	10	20					
75	154.4	151.63	50	10	20					
76	156.5	153.66	50	10	20					
78	160.5	157.70	70	10	30					
80	164.5	161.74	70	10	30					
85	174.6	171.85	70	10	30					
90	184.7	181.95	70	10	30					
95	194.8	192.05	70	10	30					
100	204.9	202.15	70	10	30					
110	225.1	222.37	70	10	30					
114	233.2	230.45	70	10	30					
120	245.4	242.58	70	10	30					
125	255.5	252.68	70	10	30					

SPROCKETS 1/4" X1/8"

For chain Acc. to DIN 8187
ISO/R 606

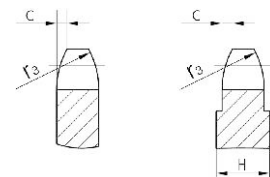
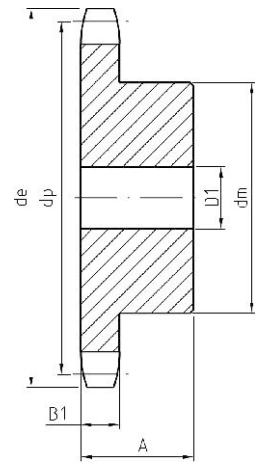

SPROCKETS mm

Tooth radius r ₃	6.4
Radius width C	0.7
Tooth width B ₁	2.9

CHAIN mm

Pitch	6.35
Internal width	3.18
Roller	3.3

H=4mm, From Z=62 the width of the plate is increased

ASA25A-1-2 | Platewheels

Z	d _e	d _p	S
			D ₁
8	19.4	16.58	6
9	21.4	18.56	6
10	23.3	20.55	6
11	25.3	22.54	8
12	27.3	24.53	8
13	29.3	26.53	8
14	31.3	28.53	8
15	33.3	30.53	8
16	35.3	32.55	8
17	37.3	34.55	8
18	39.4	36.56	8
19	41.4	38.58	8
20	43.4	40.58	8
21	45.4	42.60	8
22	47.4	44.62	8
23	49.4	46.63	8
24	51.4	48.64	8
25	53.5	50.66	8
26	55.5	52.67	8
27	57.5	54.69	8
28	59.5	56.71	8
29	61.5	58.73	8
30	63.6	60.75	8
31	65.6	62.76	10
32	67.6	64.78	10
33	69.6	66.80	10
34	71.6	68.82	10
35	73.6	70.84	10
36	75.6	72.85	10
37	77.7	74.87	10
38	79.7	76.89	10
39	81.7	78.91	10
40	83.7	80.93	10
41	85.7	82.95	10
42	87.8	84.97	10
43	89.8	86.98	10
44	91.8	89.01	10
45	93.8	91.03	10
46	95.8	93.05	10
47	97.9	95.07	10
48	99.9	97.09	10
49	101.9	99.10	10
50	103.9	101.13	10
51	105.9	103.14	12
52	108.0	105.16	12
53	110.0	107.18	12
54	112.0	109.18	12
55	114.0	111.23	12
56	116.0	113.25	12
57	118.1	115.27	12
58	120.1	117.29	12
59	122.1	119.31	12
60	124.1	121.32	12
62	128.2	125.37	12
64	132.2	129.41	12
65	134.2	131.43	12
66	136.2	133.45	14
68	140.3	137.49	14
70	144.3	141.53	14
72	148.4	145.58	14
75	154.4	151.63	14
76	156.5	153.66	14
78	160.5	157.70	16
80	164.5	161.74	16
85	174.6	171.85	16
90	184.7	181.95	16
95	194.8	192.05	16
100	204.9	202.15	16
110	225.1	222.37	16
114	233.2	230.45	16
120	245.4	242.58	16
125	255.5	252.68	16

PLATEWHEELS 1/4" X1/8"

For chain Acc. to DIN 8187
ISO/R 606

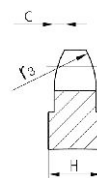
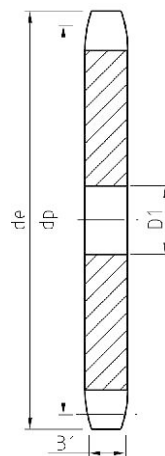

PLATEWHEELS mm

Tooth radius r ₃	6.4
Radius width C	0.7
Tooth width B ₁	2.9

CHAIN mm

Pitch	6.35
Internal width	3.18
Roller	3.3

H=4mm, From Z=51 the width of the plate is increased

05B-1-2 | Sprockets

Z	d _e	d _p	SIMPLEX			DUPLEX		
			d _m	D ₁	A	d _m	D ₂	A
8	24.0	20.90	13	6	12	12	8	18
9	26.6	23.39	15	6	12	15	8	18
10	29.2	25.89	17	8	12	17	8	18
11	31.7	28.39	18	8	13	19	8	18
12	34.2	30.91	20	8	13	21	8	18
13	36.7	33.42	23	8	13	24	8	18
14	39.2	35.95	25	8	13	26	8	18
15	41.7	38.48	28	8	13	29	8	18
16	44.3	41.01	30	8	14	32	10	20
17	46.8	43.53	30	8	14	34	10	20
18	49.3	46.07	30	8	14	37	10	20
19	51.9	48.61	30	8	14	39	10	20
20	54.4	51.14	30	8	14	40	10	20
21	57.0	53.68	35	8	14	40	10	20
22	59.5	56.21	35	8	14	40	10	20
23	62.0	58.75	35	8	14	40	10	20
24	64.6	61.29	35	8	14	40	10	20
25	67.5	63.83	35	8	14	40	10	20
26	69.5	66.37	40	10	16	50	12	22
27	72.2	68.91	40	10	16	50	12	22
28	74.8	71.45	40	10	16	50	12	22
29	77.3	73.99	40	10	16	50	12	22
30	79.8	76.53	40	10	16	50	12	22
31	82.4	79.08	40	10	16	60	12	22
32	84.9	81.61	40	10	16	60	12	22
33	87.5	84.16	40	10	16	60	12	22
34	90.0	86.70	40	10	16	60	12	22
35	92.5	89.25	40	10	16	60	12	22
36	95.0	91.79	40	10	16	60	12	22
37	97.6	94.33	40	10	16	60	12	22
38	100.2	96.88	40	10	16	60	12	22
39	102.7	99.42	40	10	16	60	12	22
40	105.3	101.97	40	10	16	60	12	22
41	107.8	104.51	58	10	20	78	12	38
42	110.4	107.05	58	10	20	78	12	38
43	112.9	109.60	58	10	20	78	12	38
44	115.5	112.14	58	10	20	78	12	38
45	118.0	114.69	58	10	20	78	12	38
46	120.6	117.23	58	10	20	78	12	38
47	123.1	119.77	58	10	20	78	12	38
48	125.6	122.32	58	10	20	78	12	38
49	128.2	124.86	58	10	20	78	12	38
50	130.7	127.41	58	10	20	78	12	38
51	133.3	129.95	78	10	20	78	12	38
52	135.8	132.49	78	10	20	78	12	38
53	138.4	135.04	78	10	20	78	12	38
54	140.9	137.59	78	10	20	78	12	38
55	143.5	140.13	78	10	20	78	12	38
56	146.0	142.68	78	10	20	78	12	38
57	148.6	145.22	78	10	20	78	12	38
58	151.0	147.77	78	10	34	78	12	38
59	153.6	150.31	78	10	34	78	12	38
60	156.2	152.86	78	10	34	78	12	38
62	162.0	157.95	78	10	34	78	12	38
64	167.1	163.04	78	10	34	78	12	38
65	169.6	165.58	78	10	34	78	12	38
66	172.2	168.13	78	10	34	78	12	38
68	177.3	173.22	78	10	34	78	12	38
70	182.4	178.31	78	10	34	78	12	38
72	187.5	183.40	78	10	34	78	12	38
75	195.1	191.04	78	10	34	78	12	38
76	197.7	193.59	78	10	34	78	12	38
78	202.8	198.68	*78	10	34	*78	12	38
80	207.9	203.77	*78	10	34	*78	12	38
85	220.6	216.50	*78	10	34	*88	12	43
90	233.4	229.23	*78	10	34	*88	12	43
95	246.1	241.96	*78	10	34	*88	12	43
100	258.9	254.68	*78	10	34	*88	12	43
110	284.3	280.15	*88	10	39	*88	12	43
114	294.5	290.33	*88	10	39	*88	12	43
120	310.0	305.61	*88	10	39	*88	12	43
125	322.5	318.34	*88	10	39	*88	12	43

SPROCKETS 8X3mm

For chain Acc. to DIN 8187
ISO/R 606

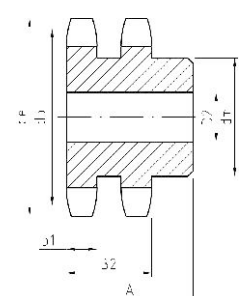
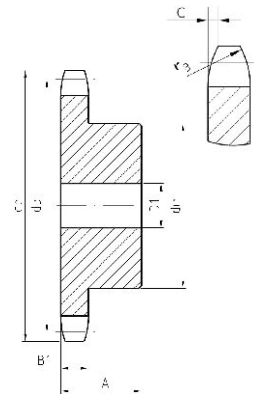

SPROCKETS mm

Tooth radius r _s	8
Radius width C	1.0
Tooth width B ₁	2.8
Tooth width b ₁	2.7
Tooth width B ₂	8.3

CHAIN mm

Pitch	8
Internal width	3
Roller	5

Material: C 45
***Weld on hub**

05A-1-2 | Platewheels

Z	d _e	d _p	S	D
			D ₁	D ₂
8	24.0	20.90	6	8
9	26.6	23.39	6	8
10	29.2	25.89	8	8
11	31.7	28.39	8	8
12	34.2	30.91	8	8
13	36.7	33.42	8	8
14	39.2	35.95	8	8
15	41.7	38.48	8	8
16	44.3	41.01	8	10
17	46.8	43.53	8	10
18	49.3	46.07	8	10
19	51.9	48.61	8	10
20	54.4	51.14	8	10
21	57.0	53.68	8	10
22	59.5	56.21	8	10
23	62.0	58.75	8	10
24	64.6	61.29	8	10
25	67.5	63.83	8	10
26	69.5	66.37	10	12
27	72.2	68.91	10	12
28	74.8	71.45	10	12
29	77.3	73.99	10	12
30	79.8	76.53	10	12
31	82.4	79.08	10	12
32	84.9	81.61	10	12
33	87.5	84.16	10	12
34	90.0	86.70	10	12
35	92.5	89.25	10	12
36	95.0	91.79	10	12
37	97.6	94.33	10	12
38	100.2	96.88	10	12
39	102.7	99.42	10	12
40	105.3	101.97	10	12
41	107.8	104.51	12	14
42	110.4	107.05	12	14
43	112.9	109.60	12	14
44	115.5	112.14	12	14
45	118.0	114.69	12	14
46	120.6	117.23	12	14
47	123.1	119.77	12	14
48	125.6	122.32	12	14
49	128.2	124.86	12	14
50	130.7	127.41	12	14
51	133.3	129.95	14	16
52	135.8	132.49	14	16
53	138.4	135.04	14	16
54	140.9	137.59	14	16
55	143.5	140.13	14	16
56	146.0	142.68	14	16
57	148.6	145.22	14	16
58	151.0	147.77	14	16
59	153.6	150.31	14	16
60	156.2	152.86	14	16
62	162.0	157.95	16	20
64	167.1	163.04	16	20
65	169.6	165.58	16	20
66	172.2	168.13	16	20
68	177.3	173.22	16	20
70	182.4	178.31	16	20
72	187.5	183.40	20	20
75	195.1	191.04	20	20
76	197.7	193.59	20	20
78	202.8	198.68	20	20
80	207.9	203.77	20	20
85	220.6	216.50	20	20
90	233.4	229.23	20	20
95	246.1	241.96	20	20
100	258.9	254.68	20	20
110	284.3	280.15	20	20
114	294.5	290.33	20	20
120	310.0	305.61	20	20
125	322.5	318.34	20	20

PLATEWHEELS 8X3mm

For chain Acc. to DIN 8187
ISO/R 606

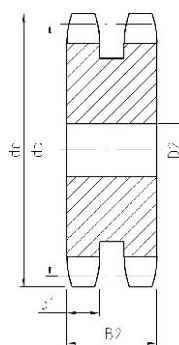
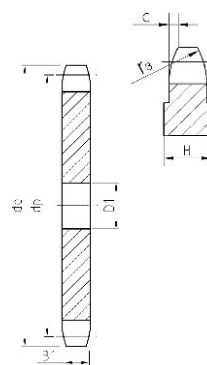

PLATEWHEELS mm

Tooth radius r ₃	8
Radius width C	1.0
Tooth width B ₁	2.8
Tooth width b ₁	2.7
Tooth width B ₂	8.3

CHAIN mm

Pitch	8
Internal width	3
Roller	5

H=4mm, From Z=46 the width of the plate is increased

06B-1-2-3 | Sprockets

SPROCKETS 3/8" X7/32"

For chain Acc. to DIN 8187
ISO/R 606



Sprockets

Z	d _e	d _p	SIMPLEX			DUPLEX			TRIPLEX		
			d _m	D ₁	A	d _m	D ₂	A	d _m	D ₃	A
8	28.0	24.89	15	8	20	15	8	22	15	8	32
9	31.0	27.85	18	8	20	18	8	22	18	8	32
10	34.0	30.82	20	8	20	20	8	22	20	10	32
11	37.0	33.80	22	8	25	22	10	25	22	10	35
12	40.0	36.80	25	8	25	25	10	25	25	10	35
13	43.0	39.79	28	10	25	28	10	25	28	10	35
14	46.3	42.80	31	10	25	31	10	25	31	12	35
15	49.3	45.81	34	10	25	34	10	25	34	12	35
16	52.3	48.82	37	10	28	37	12	30	37	12	35
17	55.3	51.83	40	10	28	40	12	30	40	12	35
18	58.3	54.85	43	10	28	43	12	30	43	12	35
19	61.3	57.87	45	10	28	46	12	30	46	12	35
20	64.3	60.89	46	10	28	49	12	30	49	12	35
21	68.0	63.91	48	12	28	52	12	30	52	14	40
22	71.0	66.93	50	12	28	55	12	30	55	14	40
23	73.5	69.95	52	12	28	58	12	30	58	14	40
24	77.0	72.97	54	12	28	61	12	30	61	14	40
25	80.0	76.00	57	12	28	64	12	30	64	14	40
26	83.0	79.02	60	12	28	67	12	30	67	14	40
27	86.0	82.05	60	12	28	70	12	30	70	14	40
28	89.0	85.07	60	12	28	73	12	30	73	14	40
29	92.0	88.09	60	12	28	76	12	30	76	14	40
30	94.7	91.12	60	12	28	79	12	30	79	14	40
31	98.3	94.15	65	14	30	80	16	30	80	16	40
32	101.3	97.17	65	14	30	80	16	30	80	16	40
33	104.3	100.20	65	14	30	80	16	30	80	16	40
34	107.3	103.23	65	14	30	80	16	30	85	16	40
35	110.4	106.26	65	14	30	80	16	30	85	16	40
36	113.4	109.29	70	14	30	90	16	30	90	16	40
37	116.4	112.32	70	14	30	90	16	30	90	16	40
38	119.5	115.35	70	14	30	90	16	30	90	16	40
39	122.5	118.37	70	14	30	90	16	30	90	16	40
40	125.5	121.40	70	14	30	90	16	30	90	16	40
41	128.5	124.43	78	14	32	90	16	40	90	16	56
42	131.6	127.46	78	14	32	90	16	40	90	16	56
43	134.6	130.49	78	14	32	90	16	40	90	16	56
44	137.6	133.52	78	14	32	90	16	40	90	16	56
45	140.7	136.55	78	14	32	90	16	40	90	16	56
46	143.7	139.58	78	14	32	90	16	40	90	16	56
47	146.7	142.61	78	14	32	90	16	40	90	16	56
48	149.7	145.64	78	14	32	90	16	40	90	16	56
49	152.7	148.66	78	14	32	90	16	40	90	16	56
50	155.7	151.69	78	14	32	90	16	40	90	16	56
51	158.7	154.72	78	14	32	90	16	40	90	16	56
52	161.8	157.75	78	14	32	90	16	40	90	16	56
53	164.8	160.78	78	14	32	90	16	40	90	16	56
54	167.8	163.82	78	14	32	90	16	40	90	16	56
55	170.8	166.85	78	14	32	90	16	40	90	16	56
56	173.8	169.88	78	14	32	90	16	40	90	16	56
57	176.9	172.91	78	14	32	90	16	40	90	16	56
58	179.9	175.93	78	14	32	90	16	40	90	16	56
59	183.0	178.96	78	14	32	90	16	40	90	16	56
60	186.0	181.99	78	14	32	90	16	40	90	16	56
62	192.1	188.06	78	14	32	90	16	40	90	16	56
64	198.2	194.12	78	14	32	90	16	40	90	16	56
65	201.6	197.15	*78	14	32	*90	16	40	*90	16	56
66	204.6	200.18	*78	14	32	*90	16	40	*90	16	56
68	210.7	206.24	*78	14	32	*90	16	40	*90	16	56
70	216.7	212.30	*78	14	32	*90	16	40	*90	16	56
72	222.8	218.37	*78	14	32	*90	16	40	*90	16	56
75	231.9	227.46	*78	14	32	*90	16	40	*90	16	56
76	234.9	230.49	*78	14	32	*90	16	40	*90	16	56
78	241.0	236.55	*78	14	32	*90	16	40	*90	16	56
80	247.1	242.61	*78	14	32	*90	16	40	*90	16	56
85	262.2	257.77	*80	14	32	*90	16	40	*90	16	56
90	277.4	272.93	*80	14	32	*90	16	40	*90	16	56
95	292.5	288.08	*80	14	32	*90	16	40	*90	16	56
100	307.7	303.25	*80	14	32	*90	16	40	*90	16	56
110	338.0	333.55	*80	14	32	*90	16	40	*90	16	56
114	349.5	345.68	*80	14	32	*90	16	40	*90	16	56
120	368.3	363.86	*80	14	32	*90	16	40	*90	16	56
125	383.5	379.02	*80	14	32	*90	16	40	*90	16	56

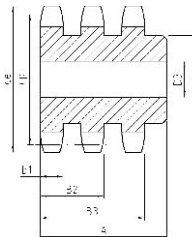
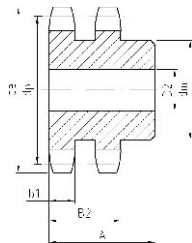
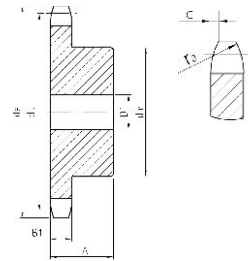

SPROCKETS mm

Tooth radius r ₃	10
Radius width C	1
Tooth width B ₁	5.3
Tooth width b ₁	5.2
Tooth width B ₂	15.4
Tooth width B ₃	25.6

CHAIN mm

Pitch	9.525
Internal width	5.72
Roller	6.35

Material: C 45
***Weld on hub**

06A-1-2-3 | Platewheels

Z	d _e	d _p	S	D	T
			D ₁	D ₂	D ₃
8	28.0	24.89	6	8	8
9	31.0	27.85	8	8	8
10	34.0	30.82	8	8	10
11	37.0	33.80	8	10	10
12	40.0	36.80	8	10	10
13	43.0	39.79	8	10	10
14	46.3	42.80	8	10	12
15	49.3	45.81	8	10	12
16	52.3	48.82	10	12	12
17	55.3	51.83	10	12	12
18	58.3	54.85	10	12	12
19	61.3	57.87	10	12	12
20	64.3	60.89	10	12	12
21	68.0	63.91	10	12	14
22	71.0	66.93	10	12	14
23	73.5	69.95	10	12	14
24	77.0	72.97	10	12	14
25	80.0	76.02	10	12	14
26	83.0	79.02	10	12	14
27	86.0	82.02	10	12	14
28	89.0	85.07	10	12	14
29	92.0	88.09	10	12	14
30	94.7	91.12	10	12	14
31	98.3	94.15	12	14	16
32	101.3	97.17	12	14	16
33	104.3	100.20	12	14	16
34	107.3	103.23	12	14	16
35	110.4	106.26	12	14	16
36	113.4	109.29	12	14	16
37	116.4	112.32	12	14	16
38	119.5	115.35	12	14	16
39	122.5	118.37	12	14	16
40	125.5	121.40	12	14	16
41	128.5	124.43	16	16	16
42	131.6	127.46	16	16	16
43	134.6	130.49	16	16	16
44	137.6	133.52	16	16	16
45	140.7	136.55	16	16	16
46	143.7	139.58	16	16	16
47	146.7	142.61	16	16	16
48	149.7	145.64	16	16	16
49	152.7	148.66	16	16	16
50	155.7	151.69	16	16	16
51	158.7	154.72	16	16	20
52	161.8	157.75	16	16	20
53	164.8	160.78	16	16	20
54	167.8	163.82	16	16	20
55	170.8	166.85	16	16	20
56	173.8	169.88	16	16	20
57	176.9	172.91	16	16	20
58	179.9	175.93	16	16	20
59	183.0	178.96	16	16	20
60	186.0	181.99	16	16	20
62	192.1	188.06	20	20	20
64	198.2	194.12	20	20	20
65	201.6	197.15	20	20	20
66	204.6	200.18	20	20	25
68	210.7	206.24	20	20	25
70	216.7	212.30	20	20	25
72	222.8	218.37	20	20	25
75	231.9	227.46	20	20	25
76	234.9	230.49	20	20	25
78	241.0	236.55	20	20	25
80	247.1	242.61	20	20	25
85	262.2	257.77	20	20	25
90	277.4	272.93	20	20	25
95	292.5	288.08	20	20	25
100	307.7	303.25	20	20	25
110	338.0	333.55	20	20	25
114	349.5	345.68	20	20	25
120	368.3	363.86	20	20	25
125	383.5	379.02	20	20	25

PLATEWHEELS 3/8" X7/32"

For chain Acc. to DIN 8187
ISO/R 606

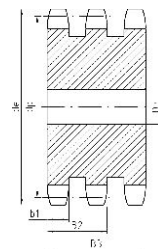
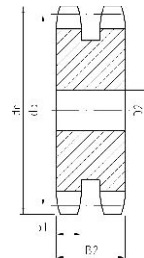
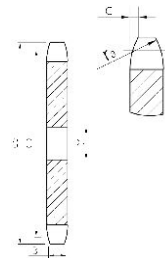

PLATEWHEELS mm

Tooth radius r _s	10
Radius width C	1
Tooth width B ₁	5.3
Tooth width b ₁	5.2
Tooth width B ₂	15.4
Tooth width B ₃	25.6

CHAIN mm

Pitch	9.525
Internal width	5.72
Roller	6.35

H=4mm, From Z=100 the width of the plate is increased

081B-1 | Sprockets

Z	d _e	d _p	SIMPLEX							
			d _m	D ₁	A					
8	37.2	33.18	21	8	14					
9	41.5	37.13	25	8	14					
10	46.2	41.10	28	8	14					
11	49.6	45.07	31	8	16					
12	53.9	49.07	35	8	16					
13	58.4	53.06	39	8	16					
14	62.8	57.07	43	8	16					
15	66.8	61.09	47	8	16					
16	70.9	65.10	50	10	18					
17	74.9	69.11	50	10	18					
18	78.9	73.14	50	10	18					
19	82.9	77.16	50	10	18					
20	86.9	81.19	50	10	18					
21	91.0	85.22	60	12	20					
22	95.0	89.24	60	12	20					
23	99.0	93.27	60	12	20					
24	103.0	97.29	60	12	20					
25	107.1	101.33	60	12	20					
26	111.2	105.36	70	16	20					
27	115.4	109.40	70	16	20					
28	119.4	113.42	70	16	20					
29	123.4	117.46	70	16	20					
30	127.5	121.50	70	16	20					
31	131.5	125.54	70	16	20					
32	135.5	129.56	70	16	20					
33	139.6	133.60	70	16	20					
34	143.6	137.64	70	16	20					
35	147.6	141.68	70	16	20					
36	151.7	145.72	70	16	25					
37	155.7	149.76	70	16	25					
38	159.8	153.80	70	16	25					
39	163.8	157.83	70	16	25					
40	167.8	161.87	70	16	25					
41	171.4	165.91	78	16	32					
42	175.4	169.95	78	16	32					
43	179.5	173.99	78	16	32					
44	183.5	178.03	78	16	32					
45	187.5	182.07	78	16	32					
46	191.6	186.10	78	16	32					
47	195.6	190.14	78	16	32					
48	199.7	194.18	78	16	32					
49	203.7	198.22	*78	16	32					
50	207.8	202.26	*78	16	32					
51	211.8	206.30	*78	16	32					
52	215.9	210.34	*78	16	32					
53	219.9	214.37	*78	16	32					
54	224.0	218.43	*78	16	32					
55	228.0	222.46	*78	16	32					
56	232.1	226.50	*78	16	32					
57	236.1	230.54	*78	16	32					
58	240.2	234.58	*78	16	32					
59	244.2	238.62	*78	16	32					
60	248.2	242.66	*78	16	32					
62	256.7	250.75	*78	16	32					
64	264.8	258.82	*78	16	32					
65	268.8	262.86	*78	16	32					
66	272.9	266.90	*78	16	32					
68	280.9	274.99	*78	16	32					
70	289.0	283.07	*78	16	32					
72	297.1	291.16	*78	16	32					
76	313.3	307.33	*78	16	32					
78	321.4	315.40	*78	16	32					
80	329.4	323.48	*78	16	32					
85	349.7	343.70	*80	16	32					
90	369.9	363.90	*80	16	32					
95	390.1	384.10	*80	16	32					
100	410.3	404.31	*80	16	32					
110	450.7	444.74	*80	16	32					
114	466.9	460.90	*80	16	32					
120	491.2	485.16	*80	16	32					
125	511.4	505.37	*80	16	32					

SPROCKETS 1/2" X1/8"

For chain Acc. to DIN 8187
ISO/R 606

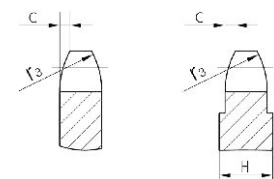
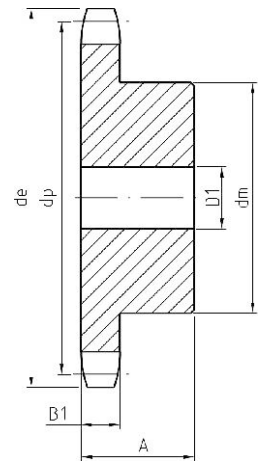

SPROCKETS mm

Tooth radius r_s 13
Radius width C 1.3
Tooth width B₁ 3

CHAIN mm

Pitch 12.7
Internal width 3.3
Roller 7.75

H=5mm, From Z=31 the width of the plate is increased

081A-1 | Platewheels

Z	d _e	d _p	S			
			D ₁			
8	37.2	33.18	8			
9	41.5	37.13	8			
10	46.2	41.10	8			
11	49.6	45.07	8			
12	53.9	49.07	8			
13	58.4	53.06	8			
14	62.8	57.07	8			
15	66.8	61.09	8			
16	70.9	65.10	8			
17	74.9	69.11	8			
18	78.9	73.14	8			
19	82.9	77.16	8			
20	86.9	81.19	8			
21	91.0	85.22	8			
22	95.0	89.24	10			
23	99.0	93.27	10			
24	103.0	97.29	10			
25	107.1	101.33	10			
26	111.2	105.36	12			
27	115.4	109.40	12			
28	119.4	113.42	12			
29	123.4	117.46	12			
30	127.5	121.50	12			
31	131.5	125.54	12			
32	135.5	129.56	12			
33	139.6	133.60	12			
34	143.6	137.64	12			
35	147.6	141.68	12			
36	151.7	145.72	16			
37	155.7	149.76	16			
38	159.8	153.80	16			
39	163.8	157.83	16			
40	167.8	161.87	16			
41	171.4	165.91	16			
42	175.4	169.95	16			
43	179.5	173.99	16			
44	183.5	178.03	16			
45	187.5	182.07	16			
46	191.6	186.10	20			
47	195.6	190.14	20			
48	199.7	194.18	20			
49	203.7	198.22	20			
50	207.8	202.26	20			
51	211.8	206.30	20			
52	215.9	210.34	20			
53	219.9	214.37	20			
54	224.0	218.43	20			
55	228.0	222.46	20			
56	232.1	226.50	20			
57	236.1	230.54	20			
58	240.2	234.58	20			
59	244.2	238.62	20			
60	248.2	242.66	20			
62	256.7	250.75	20			
64	264.8	258.82	20			
65	268.8	262.86	20			
66	272.9	266.90	25			
68	280.9	274.99	25			
70	289.0	283.07	25			
72	297.1	291.16	25			
76	313.3	307.33	25			
78	321.4	315.40	25			
80	329.4	323.48	25			
85	349.7	343.70	25			
90	369.9	363.90	25			
95	390.1	384.10	25			
100	410.3	404.31	25			
110	450.7	444.74	25			
114	466.9	460.90	25			
120	491.2	485.16	25			
125	511.4	505.37	25			

PLATEWHEELS 1/2" X1/8"

For chain Acc. to DIN 8187
ISO/R 606

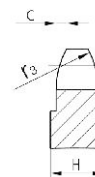
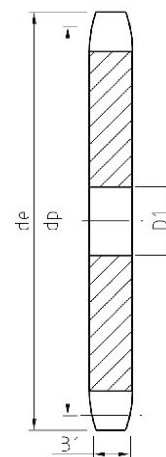

PLATEWHEELS mm

Tooth radius r ₃	13
Radius width C	1.3
Tooth width B ₁	3

CHAIN mm

Pitch	12.7
Internal width	3.3
Roller	7.75

H=4mm, From Z=30 the width of the plate is increased
H=6mm, From Z=90 the width of the plate is increased

083B-1/084B-1 | Sprockets

Z	d _e	d _p	SIMPLEX								
			d _m	D ₁	A						
8	38.5	33.18	21	8	14						
9	41.5	37.13	25	8	14						
10	46.2	41.10	28	8	14						
11	49.6	45.07	31	8	16						
12	53.9	49.07	35	8	16						
13	58.4	53.06	39	8	16						
14	62.8	57.07	43	8	16						
15	66.8	61.09	47	8	16						
16	70.9	65.10	50	10	18						
17	74.9	69.11	50	10	18						
18	78.9	73.14	50	10	18						
19	82.9	77.16	50	10	18						
20	86.9	81.19	50	10	18						
21	91.0	85.22	60	12	20						
22	95.0	89.24	60	12	20						
23	99.0	93.27	60	12	20						
24	103.0	97.29	60	12	20						
25	107.1	101.33	60	12	20						
26	111.2	105.36	70	16	20						
27	115.4	109.40	70	16	20						
28	119.4	113.42	70	16	20						
29	123.4	117.46	70	16	20						
30	127.5	121.50	70	16	20						
31	131.5	125.54	70	16	20						
32	135.5	129.56	70	16	20						
33	139.6	133.60	70	16	20						
34	143.6	137.64	70	16	20						
35	147.6	141.68	70	16	20						
36	151.7	145.72	70	16	25						
37	155.7	149.76	70	16	25						
38	159.8	153.80	70	16	25						
39	163.8	157.83	70	16	25						
40	167.8	161.87	70	16	25						
41	171.4	165.91	78	16	32						
42	175.4	169.95	78	16	32						
43	179.5	173.99	78	16	32						
44	183.5	178.03	78	16	32						
45	187.5	182.07	78	16	32						
46	191.6	186.10	78	16	32						
47	195.6	190.14	78	16	32						
48	199.7	194.18	78	16	32						
49	203.7	198.22	*78	16	32						
50	207.8	202.26	*78	16	32						
51	211.8	206.30	*78	16	32						
52	215.9	210.34	*78	16	32						
53	219.9	214.37	*78	16	32						
54	224.0	218.43	*78	16	32						
55	228.0	222.46	*78	16	32						
56	232.1	226.50	*78	16	32						
57	236.1	230.54	*78	16	32						
58	240.2	234.58	*78	16	32						
59	244.2	238.62	*78	16	32						
60	248.2	242.66	*78	16	32						
62	256.7	250.75	*78	16	32						
64	264.8	258.82	*78	16	32						
65	268.8	262.86	*78	16	32						
66	272.9	266.90	*78	16	32						
68	280.9	274.99	*78	16	32						
70	289.0	283.07	*78	16	32						
72	297.1	291.16	*78	16	32						
76	313.3	307.33	*78	16	32						
78	321.4	315.40	*78	16	32						
80	329.4	323.48	*78	16	32						
85	349.7	343.70	*80	16	32						
90	369.9	363.90	*80	16	32						
95	390.1	384.10	*80	16	32						
100	410.3	404.31	*80	16	32						
110	450.7	444.74	*80	16	32						
114	466.9	460.90	*80	16	32						
120	491.2	485.16	*80	16	32						
125	511.4	505.37	*80	16	32						

SPROCKETS 1/2" X3/16"

For chain Acc. to DIN 8187
ISO/R 606

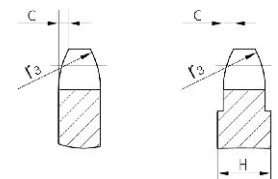
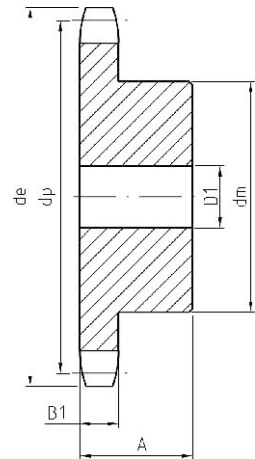

SPROCKETS mm

Tooth radius r ₃	13
Radius width C	1.3
Tooth width B ₁	4.5

CHAIN mm

Pitch	12.7
Internal width	4.88
Roller	7.75

Material: C 45
*Weld on hub

083A-1/084A-1 | Platewheels

PLATEWHEELS 1/2" X3/16"

For chain Acc. to DIN 8187
ISO/R 606

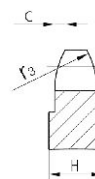
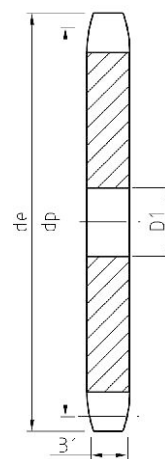

PLATEWHEELS mm

Tooth radius r_s	13
Radius width C	1.3
Tooth width B_1	4.5

CHAIN mm

Pitch	12.7
Internal width	4.88
Roller	7.75

H=6mm, From Z=90 the width of the plate is increased

Z	d_e	d_p	S			
			D ₁			
8	38.5	33.18	8			
9	41.5	37.13	8			
10	46.2	41.10	8			
11	49.6	45.07	8			
12	53.9	49.07	8			
13	58.4	53.06	8			
14	62.8	57.07	8			
15	66.8	61.09	8			
16	70.9	65.10	8			
17	74.9	69.11	8			
18	78.9	73.14	8			
19	82.9	77.16	8			
20	86.9	81.19	8			
21	91.0	85.22	8			
22	95.0	89.24	10			
23	99.0	93.27	10			
24	103.0	97.29	10			
25	107.1	101.33	10			
26	111.2	105.36	12			
27	115.4	109.40	12			
28	119.4	113.42	12			
29	123.4	117.46	12			
30	127.5	121.50	12			
31	131.5	125.54	12			
32	135.5	129.56	12			
33	139.6	133.60	12			
34	143.6	137.64	12			
35	147.6	141.68	12			
36	151.7	145.72	16			
37	155.7	149.76	16			
38	159.8	153.80	16			
39	163.8	157.83	16			
40	167.8	161.87	16			
41	171.4	165.91	16			
42	175.4	169.95	16			
43	179.5	173.99	16			
44	183.5	178.03	16			
45	187.5	182.07	16			
46	191.6	186.10	20			
47	195.6	190.14	20			
48	199.7	194.18	20			
49	203.7	198.22	20			
50	207.8	202.26	20			
51	211.8	206.30	20			
52	215.9	210.34	20			
53	219.9	214.37	20			
54	224.0	218.43	20			
55	228.0	222.46	20			
56	232.1	226.50	20			
57	236.1	230.54	20			
58	240.2	234.58	20			
59	244.2	238.62	20			
60	248.2	242.66	20			
62	256.7	250.75	20			
64	264.8	258.82	20			
65	268.8	262.86	20			
66	272.9	266.90	25			
68	280.9	274.99	25			
70	289.0	283.07	25			
72	297.1	291.16	25			
76	313.3	307.33	25			
78	321.4	315.40	25			
80	329.4	323.48	25			
85	349.7	343.70	25			
90	369.9	363.90	25			
95	390.1	384.10	25			
100	410.3	404.31	25			
110	450.7	444.74	25			
114	466.9	460.90	25			
120	491.2	485.16	25			
125	511.4	505.37	25			

085B-1 | Sprockets



Z	d _e	d _p	SIMPLEX		
			d _m	D ₁	A
8	38.5	33.18	20	10	25
9	41.5	37.13	24	10	25
10	46.2	41.10	26	10	25
11	49.6	45.07	29	10	25
12	53.9	49.07	33	10	28
13	58.4	53.06	37	10	28
14	62.8	57.07	41	10	28
15	66.8	61.09	45	10	28
16	70.9	65.10	50	12	28
17	74.9	69.11	52	12	28
18	78.9	73.14	56	12	28
19	82.9	77.16	60	12	28
20	86.9	81.19	64	12	28
21	91.0	85.22	68	14	28
22	95.0	89.24	70	14	28
23	99.0	93.27	70	14	28
24	103.0	97.29	70	14	28
25	107.1	101.33	70	14	28
26	111.2	105.36	70	16	30
27	115.4	109.40	70	16	30
28	119.4	113.42	70	16	30
29	123.4	117.46	80	16	30
30	127.5	121.50	80	16	30
31	131.5	125.54	90	16	30
32	135.5	129.56	90	16	30
33	139.6	133.60	90	16	30
34	143.6	137.64	90	16	30
35	147.6	141.68	90	16	30
36	151.7	145.72	90	16	35
37	155.7	149.76	90	16	35
38	159.8	153.80	90	16	35
39	163.8	157.83	90	16	35
40	167.8	161.87	90	16	35
41	171.4	165.91	90	16	40
42	175.4	169.95	90	16	40
43	179.5	173.99	90	16	40
44	183.5	178.03	90	16	40
45	187.5	182.07	90	16	40
46	191.6	186.10	90	16	40
47	195.6	190.14	90	16	40
48	199.7	194.18	90	16	40
49	203.7	198.22	*90	16	40
50	207.8	202.26	*90	16	40
51	211.8	206.30	*90	16	40
52	215.9	210.34	*90	16	40
53	219.9	214.37	*90	16	40
54	224.0	218.43	*90	16	40
55	228.0	222.46	*90	16	40
56	232.1	226.50	*90	16	40
57	236.1	230.54	*90	16	40
58	240.2	234.58	*90	16	40
59	244.2	238.62	*90	16	40
60	248.2	242.66	*90	16	40
62	256.7	250.75	*90	16	40
64	264.8	258.82	*90	16	40
65	268.8	262.86	*90	16	40
66	272.9	266.90	*90	16	40
68	280.9	274.99	*90	16	40
70	289.0	283.07	*90	16	40
72	297.1	291.16	*90	16	40
76	313.3	307.33	*90	16	40
78	321.4	315.40	*90	16	40
80	329.4	323.48	*90	16	40
85	349.7	343.70	*90	16	40
90	369.9	363.90	*90	16	40
95	390.1	384.10	*90	16	40
100	410.3	404.31	*90	16	40
110	450.7	444.74	*90	16	40
114	466.9	460.90	*90	16	40
120	491.2	485.16	*90	16	40
125	511.4	505.37	*90	16	40

SPROCKETS 1/2" X1/4" Roller7.75

For chain Acc. to DIN 8187
ISO/R 606

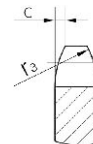
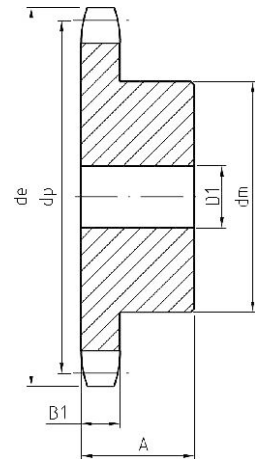

SPROCKETS mm

Tooth radius r ₃	13
Radius width C	1.3
Tooth width B ₁	5.9

CHAIN mm

Pitch	12.7
Internal width	6.4
Roller	7.75

Material: C 45
***Weld on hub**

085A-1 | Platewheels



Z	d _e	d _p	S			
			D ₁			
8	38.5	33.18	8			
9	41.5	37.13	8			
10	46.2	41.10	8			
11	49.6	45.07	8			
12	53.9	49.07	8			
13	58.4	53.06	8			
14	62.8	57.07	8			
15	66.8	61.09	8			
16	70.9	65.10	8			
17	74.9	69.11	8			
18	78.9	73.14	8			
19	82.9	77.16	8			
20	86.9	81.19	8			
21	91.0	85.22	10			
22	95.0	89.24	10			
23	99.0	93.27	10			
24	103.0	97.29	10			
25	107.1	101.33	10			
26	111.2	105.36	12			
27	115.4	109.40	12			
28	119.4	113.42	12			
29	123.4	117.46	12			
30	127.5	121.50	12			
31	131.5	125.54	12			
32	135.5	129.56	12			
33	139.6	133.60	12			
34	143.6	137.64	12			
35	147.6	141.68	12			
36	151.7	145.72	16			
37	155.7	149.76	16			
38	159.8	153.80	16			
39	163.8	157.83	16			
40	167.8	161.87	16			
41	171.4	165.91	16			
42	175.4	169.95	16			
43	179.5	173.99	16			
44	183.5	178.03	16			
45	187.5	182.07	16			
46	191.6	186.10	20			
47	195.6	190.14	20			
48	199.7	194.18	20			
49	203.7	198.22	20			
50	207.8	202.26	20			
51	211.8	206.30	20			
52	215.9	210.34	20			
53	219.9	214.37	20			
54	224.0	218.43	20			
55	228.0	222.46	20			
56	232.1	226.50	20			
57	236.1	230.54	20			
58	240.2	234.58	20			
59	244.2	238.62	20			
60	248.2	242.66	20			
62	256.7	250.75	20			
64	264.8	258.82	20			
65	268.8	262.86	20			
66	272.9	266.90	25			
68	280.9	274.99	25			
70	289.0	283.07	25			
72	297.1	291.16	25			
76	313.3	307.33	25			
78	321.4	315.40	25			
80	329.4	323.48	25			
85	349.7	343.70	25			
90	369.9	363.90	25			
95	390.1	384.10	25			
100	410.3	404.31	25			
110	450.7	444.74	25			
114	466.9	460.90	25			
120	491.2	485.16	25			
125	511.4	505.37	25			

PLATEWHEELS 1/2" X1/4" Roller7.75

For chain Acc. to DIN 8187
ISO/R 606

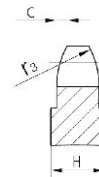
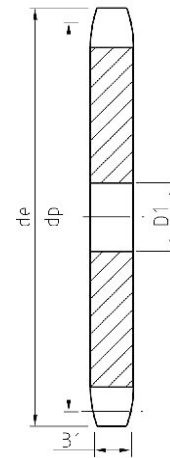

PLATEWHEELS mm

Tooth radius r ₃	13
Radius width C	1.3
Tooth width B ₁	5.9

CHAIN mm

Pitch	12.7
Internal width	6.4
Roller	7.75

Z	d _e	d _p	SIMPLEX		
			d _m	D ₁	A
8	37.2	33.18	20	10	25
9	41.0	37.13	24	10	25
10	45.2	41.10	26	10	25
11	48.7	45.07	29	10	25
12	53.0	49.07	33	10	28
13	57.4	53.06	37	10	28
14	61.8	57.07	41	10	28
15	65.5	61.09	45	10	28
16	69.5	65.10	50	12	28
17	73.6	69.11	52	12	28
18	77.8	73.14	56	12	28
19	81.7	77.16	60	12	28
20	85.8	81.19	64	12	28
21	89.7	85.22	68	14	28
22	93.8	89.24	70	14	28
23	98.2	93.27	70	14	28
24	101.8	97.29	70	14	28
25	105.8	101.33	70	14	28
26	110.0	105.36	70	16	30
27	114.0	109.40	70	16	30
28	118.0	113.42	70	16	30
29	122.0	117.46	80	16	30
30	126.1	121.50	80	16	30
31	130.2	125.54	90	16	30
32	134.3	129.56	90	16	30
33	138.4	133.60	90	16	30
34	142.6	137.64	90	16	30
35	146.7	141.68	90	16	30
36	151.0	145.72	90	16	35
37	154.6	149.76	90	16	35
38	158.6	153.80	90	16	35
39	162.7	157.83	90	16	35
40	166.8	161.87	90	16	35
41	171.4	165.91	90	16	40
42	175.4	169.95	90	16	40
43	179.7	173.99	90	16	40
44	183.8	178.03	90	16	40
45	188.0	182.07	90	16	40
46	192.1	186.10	90	16	40
47	196.2	190.14	90	16	40
48	200.3	194.18	90	16	40
49	204.3	198.22	*90	16	40
50	208.3	202.26	*90	16	40
51	212.1	206.30	*90	16	40
52	216.1	210.34	*90	16	40
53	220.2	214.37	*90	16	40
54	224.1	218.43	*90	16	40
55	228.1	222.46	*90	16	40
56	232.2	226.50	*90	16	40
57	236.4	230.54	*90	16	40
58	240.5	234.58	*90	16	40
59	244.5	238.62	*90	16	40
60	248.6	242.66	*90	16	40
62	256.9	250.75	*90	16	40
64	265.1	258.82	*90	16	40
65	269.0	262.86	*90	16	40
66	273.0	266.90	*90	16	40
68	281.0	274.99	*90	16	40
70	289.0	283.07	*90	16	40
72	297.2	291.16	*90	16	40
76	313.3	307.33	*90	16	40
78	321.4	315.40	*90	16	40
80	329.4	323.48	*90	16	40
85	349.0	343.70	*90	16	40
90	369.9	363.90	*90	16	40
95	390.1	384.10	*90	16	40
100	410.3	404.31	*90	16	40
110	450.7	444.74	*90	16	40
114	466.9	460.90	*90	16	40
120	491.2	485.16	*90	16	40
125	511.3	505.37	*90	16	40

SPROCKETS 1/2" X1/4" Roller8.51

For chain Acc. to DIN 8187
ISO/R 606

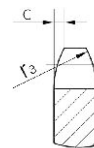
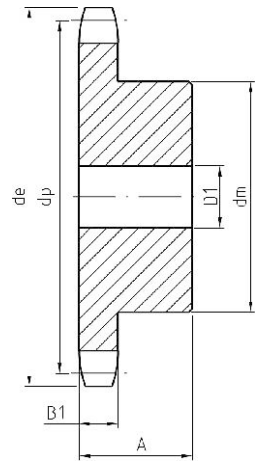

SPROCKETS mm

Tooth radius r ₃	13
Radius width C	1.3
Tooth width B ₁	5.9

CHAIN mm

Pitch	12.7
Internal width	6.4
Roller	8.51

Material: C 45
***Weld on hub**

086A-1 | Platewheels

Z	d _e	d _p	S			
			D ₁			
8	37.2	33.18	8			
9	41.0	37.13	8			
10	45.2	41.10	8			
11	48.7	45.07	8			
12	53.0	49.07	8			
13	57.4	53.06	8			
14	61.8	57.07	8			
15	65.5	61.09	8			
16	69.5	65.10	10			
17	73.6	69.11	10			
18	77.8	73.14	10			
19	81.7	77.16	10			
20	85.8	81.19	10			
21	89.7	85.22	10			
22	93.8	89.24	10			
23	98.2	93.27	10			
24	101.8	97.29	10			
25	105.8	101.33	10			
26	110.0	105.36	12			
27	114.0	109.40	12			
28	118.0	113.42	12			
29	122.0	117.46	12			
30	126.1	121.50	12			
31	130.2	125.54	12			
32	134.2	129.56	12			
33	138.4	133.60	12			
34	142.6	137.64	12			
35	146.7	141.68	12			
36	151.0	145.72	16			
37	154.6	149.76	16			
38	158.6	153.80	16			
39	162.7	157.83	16			
40	166.8	161.87	16			
41	171.4	165.91	16			
42	175.4	169.95	16			
43	179.7	173.99	16			
44	183.8	178.03	16			
45	188.0	182.07	16			
46	192.1	186.10	20			
47	196.2	190.14	20			
48	200.3	194.18	20			
49	204.3	198.22	20			
50	208.3	202.26	20			
51	212.1	206.30	20			
52	216.1	210.34	20			
53	220.2	214.37	20			
54	224.1	218.43	20			
55	228.1	222.46	20			
56	232.2	226.50	20			
57	236.4	230.54	20			
58	240.5	234.58	20			
59	244.5	238.62	20			
60	248.6	242.66	20			
62	256.9	250.75	20			
64	265.1	258.82	20			
65	269.0	262.86	20			
66	273.0	266.90	25			
68	281.0	274.99	25			
70	289.0	283.07	25			
72	297.2	291.16	25			
76	313.3	307.33	25			
78	321.4	315.40	25			
80	329.4	323.48	25			
85	349.0	343.70	25			
90	369.9	363.90	25			
95	390.1	384.10	25			
100	410.3	404.31	25			
110	450.7	444.74	25			
114	466.9	460.90	25			
120	491.2	485.16	25			
125	511.3	505.37	25			

PLATEWHEELS 1/2" X1/4" ROLLER8.51

For chain Acc. to DIN 8187
ISO/R 606

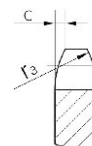
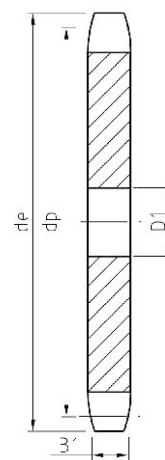

PLATEWHEELS mm

Tooth radius r ₃	13
Radius width C	1.3
Tooth width B ₁	5.9

CHAIN mm

Pitch	12.7
Internal width	6.4
Roller	8.51

08B-1-2-3 | Sprockets



Z	d _e	d _p	SIMPLEX			DUPLEX			TRIPLEX		
			d _m	D ₁	A	d _m	D ₂	A	d _m	D ₃	A
8	37.2	33.18	20	10	25	20	10	32	20	10	46
9	41.0	37.13	24	10	25	24	10	32	24	12	46
10	45.2	41.10	26	10	25	28	10	32	28	12	46
11	48.7	45.07	29	10	25	32	12	35	32	14	50
12	53.0	49.07	33	10	28	35	12	35	35	14	50
13	57.4	53.06	37	10	28	38	12	35	38	14	50
14	61.8	57.07	41	10	28	42	12	35	42	14	50
15	65.5	61.09	45	10	28	46	12	35	46	14	50
16	69.5	65.10	50	12	28	50	14	35	50	16	50
17	73.6	69.11	52	12	28	54	14	35	54	16	50
18	77.8	73.14	56	12	28	58	14	35	58	16	50
19	81.7	77.16	60	12	28	62	14	35	62	16	50
20	85.8	81.19	64	12	28	66	14	35	66	16	50
21	89.7	85.22	68	12	28	70	16	40	70	16	55
22	93.8	89.24	70	12	28	70	16	40	70	16	55
23	98.2	93.27	70	14	28	70	16	40	70	16	55
24	101.8	97.29	70	14	28	75	16	40	75	16	55
25	105.8	101.33	70	14	28	80	16	40	80	16	55
26	110.0	105.36	70	16	30	85	16	40	85	20	55
27	114.0	109.40	70	16	30	85	16	40	85	20	55
28	118.0	113.42	70	16	30	90	16	40	90	20	55
29	122.0	117.46	80	16	30	95	16	40	95	20	55
30	126.1	121.50	80	16	30	100	16	40	100	20	55
31	130.2	125.54	90	16	30	100	20	40	110	20	55
32	134.3	129.56	90	16	30	100	20	40	110	20	55
33	138.4	133.60	90	16	30	100	20	40	110	20	55
34	142.6	137.64	90	16	30	100	20	40	110	20	55
35	146.7	141.68	90	16	30	100	20	40	110	20	55
36	151.0	145.72	90	16	35	100	20	40	120	25	55
37	154.6	149.76	90	16	35	100	20	40	120	25	55
38	158.6	153.80	90	16	35	100	20	40	120	25	55
39	162.7	157.83	90	16	35	100	20	40	120	25	55
40	166.8	161.87	90	16	35	100	20	40	120	25	55
41	171.4	165.91	*90	16	40	*108	20	50	*120	25	60
42	175.4	169.94	*90	16	40	*108	20	50	*120	25	60
43	179.7	173.98	*90	16	40	*108	20	50	*120	25	60
44	183.8	178.02	*90	16	40	*108	20	50	*120	25	60
45	188.0	182.07	*90	16	40	*108	20	50	*120	25	60
46	192.1	186.10	*90	16	40	*108	20	50	*120	25	60
47	196.2	190.14	*90	16	40	*108	20	50	*120	25	60
48	200.3	194.18	*90	16	40	*108	20	50	*120	25	60
49	204.3	198.22	*90	16	40	*108	20	50	*120	25	60
50	208.3	202.26	*90	16	40	*108	20	50	*120	25	60
51	212.1	206.30	*90	16	40	*108	20	50	*120	25	60
52	216.1	210.34	*90	16	40	*108	20	50	*120	25	60
53	220.2	214.37	*90	16	40	*108	20	50	*120	25	60
54	224.1	218.43	*90	16	40	*108	20	50	*120	25	60
55	228.1	222.46	*90	16	40	*108	20	50	*120	25	60
56	232.2	226.50	*90	16	40	*108	20	50	*120	25	60
57	236.4	230.54	*90	16	40	*108	20	50	*120	25	60
58	240.5	234.58	*90	16	40	*108	20	50	*120	25	60
59	244.5	238.62	*90	16	40	*108	20	50	*120	25	60
60	248.6	242.66	*90	16	40	*108	20	50	*120	25	60
62	256.9	250.74	*90	16	40	*108	20	50	*120	25	60
64	265.1	258.82	*90	16	40	*108	20	50	*120	25	60
65	269.0	262.86	*90	16	40	*108	20	50	*120	25	60
66	273.0	266.91	*90	16	40	*108	20	50	*120	25	60
68	281.0	274.99	*90	16	40	*108	20	50	*120	25	60
70	289.0	283.07	*90	16	40	*108	20	55	*120	25	60
72	297.2	291.15	*90	16	40	*108	20	55	*120	25	60
75	309.2	303.28	*90	16	40	*108	20	55	*120	25	60
76	313.2	307.32	*90	16	40	*108	20	55	*120	25	60
78	321.4	315.40	*90	16	40	*108	20	55	*120	25	60
80	329.4	323.49	*90	16	40	*108	20	55	*120	25	60
85	349.0	343.69	*90	16	40	*110	20	55	*120	25	60
90	369.9	363.90	*90	16	40	*110	20	55	*120	25	60
95	390.1	384.11	*90	16	40	*110	20	55	*120	25	60
100	410.3	404.32	*90	16	40	*110	20	55	*120	25	60
110	450.7	444.74	*90	16	40	*110	20	55	*120	25	60
114	466.9	460.91	*90	16	40	*110	20	55	*120	25	60
120	491.2	485.16	*90	16	40	*110	20	55	*120	25	60
125	511.3	505.37	*90	16	40	*110	20	55	*120	25	60

SPROCKETS 1/2" X5/16"

For chain Acc. to DIN 8187
ISO/R 606

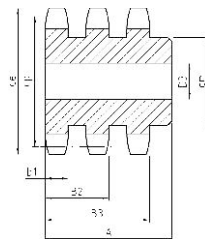
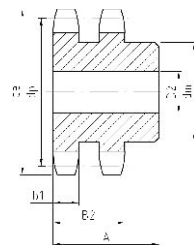
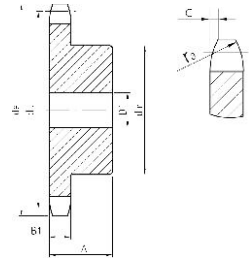

SPROCKETS mm

Tooth radius r ₃	13
Radius width C	1.3
Tooth width B ₁	7.2
Tooth width b ₁	7
Tooth width B ₂	21
Tooth width B ₃	34.9

CHAIN mm

Pitch	12.7
Internal width	7.75
Roller	8.51

Material: C 45
*Weld on hub

08A-1-2-3 | Platewheels

PLATEWHEELS 1/2" X5/16"

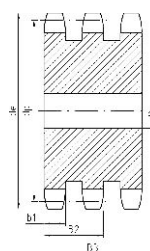
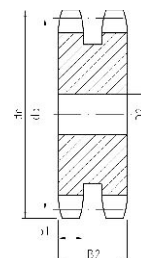
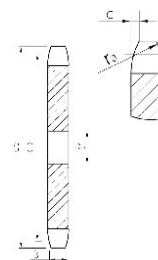
 For chain Acc. to DIN 8187
 ISO/R 606

Z	d _e	d _p	S	D	T
			D ₁	D ₂	D ₃
8	37.2	33.18	8	10	10
9	41.0	37.13	8	10	10
10	45.2	41.10	8	10	10
11	48.7	45.07	10	10	12
12	53.0	49.07	10	10	12
13	57.4	53.06	10	10	12
14	61.8	57.07	10	10	12
15	65.5	61.09	10	10	12
16	69.5	65.10	10	12	16
17	73.6	69.11	10	12	16
18	77.8	73.14	10	12	16
19	81.7	77.16	10	12	16
20	85.8	81.19	10	12	16
21	89.7	85.22	12	16	16
22	93.8	89.24	12	16	16
23	98.2	93.27	12	16	16
24	101.8	97.29	12	16	16
25	105.8	101.33	12	16	16
26	110.0	105.36	16	16	16
27	114.0	109.40	16	16	16
28	118.0	113.42	16	16	16
29	122.0	117.46	16	16	16
30	126.1	121.50	16	16	16
31	130.2	125.54	16	16	20
32	134.3	129.56	16	16	20
33	138.4	133.60	16	16	20
34	142.6	137.64	16	16	20
35	146.7	141.68	16	16	20
36	151.0	145.72	16	20	20
37	154.6	149.76	16	20	20
38	158.6	153.80	16	20	20
39	162.7	157.83	16	20	20
40	166.8	161.87	16	20	20
41	171.4	165.91	20	20	25
42	175.4	169.94	20	20	25
43	179.7	173.98	20	20	25
44	183.8	178.03	20	20	25
45	188.0	182.07	20	20	25
46	192.1	186.10	20	20	25
47	196.2	190.14	20	20	25
48	200.3	194.18	20	20	25
49	204.3	198.22	20	20	25
50	208.3	202.26	20	20	25
51	212.1	206.30	20	25	25
52	216.1	210.34	20	25	25
53	220.2	214.37	20	25	25
54	224.1	218.43	20	25	25
55	228.1	222.46	20	25	25
56	232.2	226.50	20	25	25
57	236.4	230.54	20	25	25
58	240.5	234.58	20	25	25
59	244.5	238.62	20	25	25
60	248.6	242.66	20	25	25
62	256.9	250.74	25	25	25
64	265.1	258.82	25	25	25
65	269.0	262.86	25	25	25
66	273.0	266.91	25	25	25
68	281.0	274.99	25	25	25
70	289.0	283.07	25	25	25
72	297.2	291.15	25	25	25
75	309.2	303.28	25	25	25
76	313.3	307.32	25	25	25
78	321.4	315.40	25	25	25
80	329.4	323.49	25	25	25
85	349.0	343.69	25	25	25
90	369.9	363.90	25	25	25
95	390.1	384.11	25	25	25
100	410.3	404.32	25	25	25
110	450.7	444.74	25	25	25
114	466.9	460.91	25	25	25
120	491.2	485.16	25	25	25
125	511.3	505.37	25	25	25

PLATEWHEELS mm

Tooth radius r ₃	13
Radius width C	1.3
Tooth width B ₁	7.2
Tooth width b	7
Tooth width B ₂	21
Tooth width B ₃	34.9

CHAIN mm

Pitch	12.7
Internal width	7.75
Roller	8.51

10B-1-2-3 | Sprockets

Z	d _a	d _p	SIMPLEX			DUPLEX			TRIPLEX		
			d _m	D ₁	A	d _m	D ₂	A	d _m	D ₃	A
8	47.0	41.48	25	10	25	25	12	40	25	12	55
9	52.6	46.42	30	10	25	30	12	40	30	12	55
10	57.5	51.37	35	10	25	35	12	40	35	12	55
11	63.0	56.34	37	12	30	39	14	40	39	16	55
12	68.0	61.34	42	12	30	44	14	40	44	16	55
13	73.0	66.32	47	12	30	49	14	40	49	16	55
14	78.0	71.34	52	12	30	54	14	40	54	16	55
15	83.0	76.36	57	12	30	59	14	40	59	16	55
16	88.0	81.37	60	12	30	64	16	45	64	16	60
17	93.0	86.39	60	12	30	69	16	45	69	16	60
18	98.3	91.42	70	14	30	74	16	45	74	16	60
19	103.3	96.45	70	14	30	79	16	45	79	16	60
20	108.4	101.49	75	14	30	84	16	45	84	16	60
21	113.4	106.52	75	16	30	85	16	45	85	20	60
22	118.0	111.55	80	16	30	90	16	45	90	20	60
23	123.5	116.58	80	16	30	95	16	45	95	20	60
24	128.3	121.62	80	16	30	100	16	45	100	20	60
25	134.0	126.66	80	16	30	105	16	45	105	20	60
26	139.0	131.70	85	20	35	110	20	45	110	20	60
27	144.0	136.75	85	20	35	110	20	45	110	20	60
28	148.7	141.78	90	20	35	115	20	45	115	20	60
29	153.8	146.83	90	20	35	115	20	45	115	20	60
30	158.8	151.87	90	20	35	120	20	45	120	20	60
31	163.9	156.92	95	20	35	120	20	45	120	20	60
32	168.9	161.95	95	20	35	120	20	45	120	20	60
33	174.5	167.00	95	20	35	120	20	45	120	20	60
34	179.0	172.05	95	20	35	120	20	45	120	20	60
35	184.1	177.10	95	20	35	120	20	45	120	20	60
36	189.1	182.15	100	20	35	120	20	45	120	25	60
37	194.2	187.20	100	20	35	120	20	45	120	25	60
38	199.2	192.24	100	20	35	120	20	45	120	25	60
39	204.2	197.29	100	20	35	120	20	45	120	25	60
40	209.3	202.34	100	20	35	120	20	45	120	25	60
41	214.8	207.38	*100	20	40	*120	20	50	*130	25	60
42	219.9	212.43	*100	20	40	*120	20	50	*130	25	60
43	224.9	217.48	*100	20	40	*120	20	50	*130	25	60
44	230.0	222.53	*100	20	40	*120	20	50	*130	25	60
45	235.0	227.58	*100	20	40	*120	20	50	*130	25	60
46	240.1	232.63	*100	20	40	*120	20	50	*130	25	60
47	245.1	237.68	*100	20	40	*120	20	50	*130	25	60
48	250.2	242.73	*100	20	40	*120	20	50	*130	25	60
49	255.2	247.78	*100	20	40	*120	20	50	*130	25	60
50	260.3	252.82	*100	20	40	*120	20	50	*130	25	60
51	265.3	257.87	*100	20	40	*120	20	50	*130	25	60
52	270.4	262.92	*100	20	40	*120	20	50	*130	25	60
53	275.4	267.97	*100	20	40	*120	20	50	*130	25	60
54	280.5	273.03	*100	20	40	*120	20	50	*130	25	60
55	285.5	278.08	*100	20	40	*120	20	50	*130	25	60
56	290.6	283.13	*100	20	40	*120	20	50	*130	25	60
57	296.0	288.18	*100	20	40	*120	20	50	*130	25	60
58	300.7	293.23	*100	20	43	*120	20	57	*130	25	64
59	305.7	298.28	*100	20	43	*120	20	57	*130	25	64
60	310.8	303.33	*100	20	43	*120	20	57	*130	25	64
62	321.4	313.43	*100	20	43	*120	20	57	*130	25	64
64	331.5	323.53	*100	20	43	*120	20	57	*130	25	67
65	336.5	328.58	*100	20	43	*120	20	57	*130	25	67
66	341.6	333.64	*100	20	43	*120	20	57	*130	25	67
68	351.7	343.74	*100	20	43	*120	20	57	*130	25	67
70	361.8	353.84	*100	20	43	*120	20	57	*130	25	67
72	371.9	363.94	*100	20	43	*120	20	57	*130	25	67
75	387.1	379.10	*100	20	43	*120	20	57	*130	25	67
76	392.1	384.15	*100	20	43	*120	20	57	*130	25	67
78	402.2	394.25	*100	20	43	*120	20	57	*130	25	67
80	412.3	404.36	*100	20	43	*130	20	57	*130	25	67
85	437.6	429.62	*100	20	50	*130	20	58	*130	25	67
90	462.8	454.88	*100	20	50	*130	20	58	*130	25	67
95	488.5	480.14	*100	20	50	*130	20	58	*130	25	67
100	513.4	505.40	*100	20	50	*130	20	58	*130	25	67
110	563.9	555.92	*100	20	50	*130	20	58	*130	25	67
114	584.1	576.13	*100	20	50	*130	20	58	*130	25	67
120	614.4	606.45	*100	20	50	*130	20	58	*130	25	67
125	639.7	631.51	*100	20	50	*130	20	58	*130	25	67

SPROCKETS 5/8" X3/8"

For chain Acc. to DIN 8187
ISO/R 606

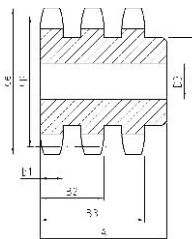
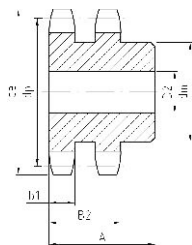
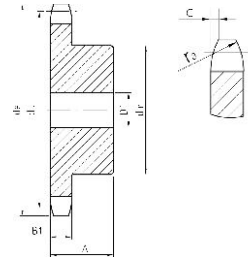

SPROCKETS mm

Tooth radius r ₁	16
Radius width C	1.6
Tooth width B ₁	9.1
Tooth width b ₁	9
Tooth width B ₂	25.5
Tooth width B ₃	42.1

CHAIN mm

Pitch	15.875
Internal width	9.65
Roller	10.16

Material: C 45
***Weld on hub**

10A-1-2-3 | Platewheels

Z	d _e	d _p	S	D	T
			D ₁	D ₂	D ₃
8	47.0	41.48	10	10	12
9	52.6	46.42	10	10	12
10	57.5	51.37	10	10	12
11	63.0	56.34	10	10	12
12	68.0	61.34	10	10	12
13	73.0	66.32	10	10	12
14	78.0	71.34	10	10	12
15	83.0	76.36	10	12	12
16	88.0	81.37	12	12	16
17	93.0	86.39	12	12	16
18	98.3	91.42	12	12	16
19	103.3	96.45	12	12	16
20	108.4	101.49	12	12	16
21	113.4	106.52	12	16	16
22	118.0	111.55	12	16	16
23	123.5	116.58	12	16	16
24	128.3	121.62	12	16	16
25	134.0	126.66	12	16	16
26	139.0	131.70	16	16	20
27	144.0	136.75	16	16	20
28	148.7	141.78	16	16	20
29	153.8	146.83	16	16	20
30	158.8	151.87	16	16	20
31	163.9	156.92	16	20	20
32	168.9	161.95	16	20	20
33	174.5	167.00	16	20	20
34	179.0	172.05	16	20	20
35	184.1	177.10	16	20	20
36	189.1	182.15	20	20	25
37	194.2	187.20	20	20	25
38	199.2	192.24	20	20	25
39	204.2	197.29	20	20	25
40	209.3	202.34	20	20	25
41	214.8	207.38	20	20	25
42	219.9	212.43	20	20	25
43	224.9	217.48	20	20	25
44	230.0	222.53	20	20	25
45	235.0	227.58	20	20	25
46	240.1	232.63	20	25	25
47	245.1	237.68	20	25	25
48	250.2	242.73	20	25	25
49	255.2	247.78	20	25	25
50	260.3	252.82	20	25	25
51	265.3	257.87	20	25	25
52	270.4	262.92	20	25	25
53	275.4	267.97	20	25	25
54	280.5	273.03	20	25	25
55	285.5	278.08	20	25	25
56	290.6	283.13	25	25	25
57	296.0	288.18	25	25	25
58	300.7	293.23	25	25	25
59	305.7	298.28	25	25	25
60	310.8	303.33	25	25	25
62	321.4	313.43	25	25	30
64	331.5	323.53	25	25	30
65	336.5	328.58	25	25	30
66	341.6	333.64	25	25	30
68	351.7	343.74	25	25	30
70	361.8	353.84	25	25	30
72	371.9	363.94	25	25	30
75	387.1	379.10	25	25	30
76	392.1	384.15	25	25	30
78	402.2	394.25	25	25	30
80	412.3	404.36	25	25	30
85	437.6	429.62	30	30	30
90	462.8	454.88	30	30	30
95	488.5	480.14	30	30	30
100	513.4	505.40	30	30	30
110	563.9	555.92	30	30	30
114	584.1	576.13	30	30	30
120	614.4	606.45	30	30	30
125	639.7	631.51	30	30	30

PLATEWHEELS 5/8" X3/8"

For chain Acc. to DIN 8187
ISO/R 606

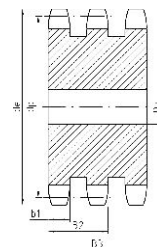
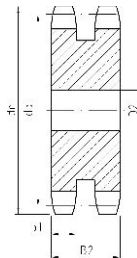
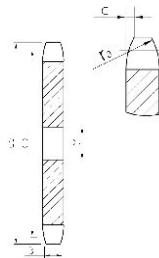

PLATEWHEELS mm

Tooth radius r ₃	16
Radius width C	1.6
Tooth width B ₁	9.1
Tooth width b ₁	9
Tooth width B ₂	25.5
Tooth width B ₃	42.1

CHAIN mm

Pitch	15.875
Internal width	9.65
Roller	10.16

12B-1-2-3 | Sprockets

Z	d _e	d _p	SIMPLEX			DUPLEX			TRIPLEX		
			d _m	D ₁	A	d _m	D ₂	A	d _m	D ₃	A
8	57.6	49.78	31	12	30	31	12	45	31	16	65
9	62.0	55.70	37	12	30	37	12	45	37	16	65
10	69.0	61.64	42	12	30	42	12	45	42	16	65
11	75.0	67.61	46	14	35	47	16	50	47	20	70
12	81.5	73.61	52	14	35	53	16	50	53	20	70
13	87.5	79.59	58	14	35	59	16	50	59	20	70
14	93.6	85.61	64	14	35	65	16	50	65	20	70
15	99.8	91.63	70	14	35	71	16	50	71	20	70
16	105.5	97.65	75	16	35	77	20	50	77	20	70
17	111.5	103.67	80	16	35	83	20	50	83	20	70
18	118.0	109.71	80	16	35	89	20	50	89	20	70
19	124.2	115.75	80	16	35	95	20	50	95	20	70
20	129.7	121.78	80	16	35	100	20	50	100	20	70
21	136.0	127.82	90	20	40	100	20	50	100	20	70
22	141.0	133.86	90	20	40	100	20	50	100	20	70
23	149.0	139.90	90	20	40	110	20	50	110	20	70
24	153.9	145.94	90	20	40	110	20	50	110	20	70
25	160.0	152.00	90	20	40	120	20	50	120	20	70
26	165.9	158.04	95	20	40	120	20	50	120	20	70
27	172.3	164.09	95	20	40	120	20	50	120	20	70
28	178.0	170.13	95	20	40	120	20	50	120	20	70
29	184.1	176.19	95	20	40	120	20	50	120	20	70
30	190.5	182.25	95	20	40	120	20	50	120	20	70
31	196.3	188.31	95	20	40	120	20	50	130	25	70
32	203.3	194.35	95	20	40	120	20	50	130	25	70
33	209.3	200.40	95	20	40	120	20	50	130	25	70
34	214.6	206.46	95	20	40	120	20	50	130	25	70
35	221.0	212.52	95	20	40	120	20	50	130	25	70
36	226.8	218.58	100	20	40	120	25	50	130	25	70
37	232.9	224.64	100	20	40	120	25	50	130	25	70
38	239.0	230.69	100	20	40	120	25	50	130	25	70
39	245.1	236.75	100	20	40	120	25	50	130	25	70
40	251.3	242.81	100	20	40	120	25	50	130	25	70
41	257.3	248.86	*110	20	56	*136	25	62	*140	25	70
42	264.5	254.92	*110	20	56	*136	25	62	*140	25	70
43	270.5	260.98	*110	20	56	*136	25	62	*140	25	70
44	276.5	267.03	*110	20	56	*136	25	62	*140	25	70
45	282.5	273.09	*110	20	56	*136	25	62	*140	25	70
46	287.9	279.15	*110	20	56	*136	25	62	*140	25	70
47	294.0	285.21	*110	20	56	*136	25	62	*140	25	70
48	300.1	291.27	*110	20	56	*136	25	62	*140	25	70
49	306.2	297.33	*110	20	56	*136	25	62	*140	25	70
50	312.3	303.39	*110	20	56	*136	25	62	*140	25	70
51	318.4	309.45	*110	20	56	*136	25	62	*140	25	70
52	324.5	315.51	*110	20	56	*136	25	62	*140	25	70
53	330.5	321.57	*110	20	56	*136	25	62	*140	25	70
54	336.6	327.63	*110	20	56	*136	25	62	*140	25	70
55	342.7	333.69	*110	20	56	*136	25	62	*140	25	70
56	348.7	339.75	*110	20	56	*136	25	62	*140	25	70
57	355.4	345.81	*110	20	56	*136	25	62	*140	25	70
58	361.5	351.87	*110	20	56	*136	25	62	*140	25	70
59	367.5	357.93	*110	20	56	*136	25	62	*140	25	70
60	373.0	363.99	*110	20	56	*136	25	62	*140	25	70
62	385.1	376.12	*110	20	56	*136	25	62	*140	25	70
64	397.2	388.24	*110	20	56	*140	25	63	*140	25	70
65	403.2	394.30	*110	20	56	*140	25	63	*140	25	70
66	409.3	400.36	*110	20	56	*140	25	63	*140	25	70
68	421.4	412.49	*110	20	56	*140	25	63	*140	25	70
70	433.6	424.61	*110	20	56	*140	25	63	*140	25	70
72	447.0	436.73	*110	20	56	*140	25	63	*140	25	70
75	463.9	454.92	*110	20	56	*140	25	63	*140	25	70
76	469.9	460.98	*110	20	56	*140	25	63	*140	25	70
78	482.1	473.10	*110	20	56	*140	25	63	*140	25	70
80	494.2	485.23	*110	20	56	*140	25	63	*140	25	70
85	524.5	515.54	*110	20	56	*140	25	63	*140	25	70
90	554.8	545.85	*110	20	56	*140	25	63	*140	25	70
95	585.1	576.17	*110	20	56	*140	25	63	*140	25	70
100	615.4	606.48	*110	20	56	*140	25	63	*140	25	70
110	676.1	667.11	*110	20	56	*140	25	63	*140	25	70
114	700.6	691.36	*110	20	56	*140	25	63	*140	25	70
120	736.7	727.74	*110	20	56	*140	25	63	*140	25	70
125	767.0	758.06	*110	20	56	*140	25	63	*140	25	70

SPROCKETS 3/4" X7/16"

For chain Acc. to DIN 8187
ISO/R 606

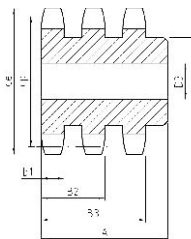
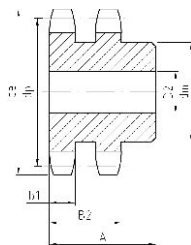
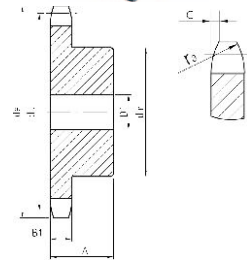

SPROCKETS mm

Tooth radius r _s	19
Radius width C	2
Tooth width B ₁	11.1
Tooth width b ₁	10.8
Tooth width B ₂	30.3
Tooth width B ₃	49.8

CHAIN mm

Pitch	19.05
Internal width	11.68
Roller	12.07

Material: C 45
***Weld on hub**

12A-1-2-3 | Platewheels

Z	d _e	d _p	S	D	T
			D ₁	D ₂	D ₃
8	57.6	49.78	10	12	12
9	62.0	55.70	10	12	12
10	69.0	61.64	10	12	12
11	75.0	67.61	12	14	16
12	81.5	73.61	14	14	16
13	87.5	79.59	14	14	16
14	93.6	85.61	14	14	16
15	99.8	91.63	14	14	16
16	105.5	97.65	14	16	16
17	111.5	103.67	14	16	16
18	118.0	109.71	14	16	16
19	124.2	115.75	14	16	16
20	129.7	121.78	14	16	16
21	136.0	127.82	16	16	20
22	141.0	133.86	16	16	20
23	149.0	139.90	16	16	20
24	153.9	145.94	16	16	20
25	160.0	152.00	16	16	20
26	165.9	158.04	16	20	20
27	172.3	164.09	16	20	20
28	178.0	170.13	16	20	20
29	184.1	176.19	16	20	20
30	190.5	182.25	16	20	20
31	196.3	188.31	20	20	25
32	203.3	194.35	20	20	25
33	209.3	200.40	20	20	25
34	214.6	206.46	20	20	25
35	221.0	212.52	20	20	25
36	226.8	218.58	20	25	25
37	232.9	224.64	20	25	25
38	239.0	230.69	20	25	25
39	245.1	236.75	20	25	25
40	251.3	242.81	20	25	25
41	257.3	248.86	25	25	25
42	264.5	254.92	25	25	25
43	270.5	260.98	25	25	25
44	276.5	267.03	25	25	25
45	282.5	273.09	25	25	25
46	287.9	279.15	25	25	25
47	294.0	285.21	25	25	25
48	300.1	291.27	25	25	25
49	306.2	297.33	25	25	25
50	312.3	303.39	25	25	25
51	318.4	309.45	25	25	25
52	324.5	315.51	25	25	25
53	330.5	321.57	25	25	25
54	336.6	327.63	25	25	25
55	342.7	333.69	25	25	25
56	348.7	339.75	25	25	30
57	355.4	345.81	25	25	30
58	361.5	351.87	25	25	30
59	367.5	357.93	25	25	30
60	373.0	363.99	25	25	30
62	385.1	376.12	25	30	30
64	397.2	388.24	25	30	30
65	403.2	394.30	25	30	30
66	409.3	400.36	30	30	30
68	421.4	412.49	30	30	30
70	433.6	424.61	30	30	30
72	447.0	436.73	30	30	30
75	463.9	454.92	30	30	30
76	469.9	460.98	30	30	30
78	482.1	473.10	30	30	30
80	494.2	485.23	30	30	30
85	524.5	515.54	30	30	30
90	554.8	545.85	30	30	30
95	585.1	576.17	30	30	30
100	615.4	606.48	30	30	30
110	676.1	667.11	30	30	30
114	700.6	691.36	30	30	30
120	736.7	727.74	30	30	30
125	767.0	758.06	30	30	30

PLATEWHEELS 3/4" X7/16"

For chain Acc. to DIN 8187
ISO/R 606

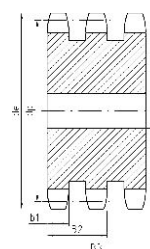
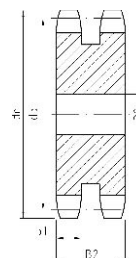
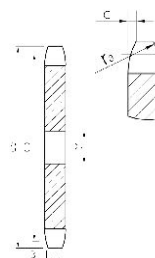

PLATEWHEELS mm

Tooth radius r _s	19
Radius width C	2
Tooth width B ₁	11.1
Tooth width b ₁	10.8
Tooth width B ₂	30.3
Tooth width B ₃	49.8

CHAIN mm

Pitch	19.05
Internal width	11.68
Roller	12.07

16B-1-2-3 | Sprockets

Z	d _e	d _p	SIMPLEX			DUPLEX			TRIPLEX		
			d _m	D ₁	A	d _m	D ₂	A	d _m	D ₃	A
8	77.0	66.37	42	16	35	42	16	65	42	20	95
9	85.0	74.27	50	16	35	50	16	65	50	20	95
10	93.0	82.19	55	16	35	56	16	65	56	20	95
11	101.5	90.14	61	16	40	64	20	70	64	25	100
12	109.0	98.14	69	16	40	72	20	70	72	25	100
13	117.0	106.12	78	16	40	80	20	70	80	25	100
14	125.0	114.15	84	16	40	88	20	70	88	25	100
15	133.0	122.17	92	16	40	96	20	70	96	25	100
16	141.0	130.20	100	20	45	104	20	70	104	25	100
17	149.0	138.22	100	20	45	112	20	70	112	25	100
18	157.0	146.28	100	20	45	120	20	70	120	25	100
19	165.2	154.33	100	20	45	128	20	70	128	25	100
20	173.2	162.38	100	20	45	130	20	70	130	25	100
21	181.2	170.43	110	20	50	130	25	70	*130	25	100
22	189.3	178.48	110	20	50	*130	25	70	*130	25	100
23	197.5	186.53	110	20	50	*130	25	70	*130	25	100
24	205.5	194.59	110	20	50	*130	25	70	*130	25	100
25	213.5	202.66	110	20	50	*130	25	70	*130	25	100
26	221.6	210.72	120	20	50	*130	25	70	*130	30	100
27	229.6	218.79	120	20	50	*130	25	70	*130	30	100
28	237.7	226.85	120	20	50	*130	25	70	*130	30	100
29	245.8	234.92	120	20	50	*130	25	70	*130	30	100
30	254.0	243.00	120	20	50	*130	25	70	*130	30	100
31	262.0	251.08	*120	25	50	*140	25	70	*140	30	100
32	270.0	259.13	*120	25	50	*140	25	70	*140	30	100
33	278.5	267.21	*120	25	50	*140	25	70	*140	30	100
34	287.0	275.28	*120	25	50	*140	25	70	*140	30	100
35	296.2	283.36	*120	25	50	*140	25	70	*140	30	100
36	304.6	291.44	*120	25	50	*140	25	70	*140	30	100
37	312.6	299.51	*120	25	50	*140	25	70	*140	30	100
38	320.7	307.59	*120	25	50	*140	25	70	*140	30	100
39	328.8	315.67	*120	25	50	*140	25	70	*140	30	100
40	336.9	323.75	*120	25	50	*140	25	70	*140	30	100
41	345.0	331.81	*125	25	68	*140	25	70	*160	30	100
42	353.0	339.89	*125	25	68	*140	25	70	*160	30	100
43	361.1	347.97	*125	25	68	*140	25	70	*160	30	100
44	369.1	356.05	*125	25	68	*140	25	70	*160	30	100
45	377.1	364.12	*125	25	68	*140	25	70	*160	30	100
46	385.2	372.20	*125	25	68	*140	25	70	*160	30	100
47	393.2	380.28	*125	25	68	*140	25	70	*160	30	100
48	401.3	388.36	*125	25	68	*140	25	70	*160	30	100
49	409.3	396.44	*125	25	68	*140	25	70	*160	30	100
50	417.4	404.52	*125	25	68	*140	25	70	*160	30	100
51	425.5	412.60	*125	25	68	*150	25	85	*180	30	110
52	433.6	420.68	*125	25	68	*150	25	85	*180	30	110
53	441.7	428.76	*125	25	68	*150	25	85	*180	30	110
54	448.3	436.84	*125	25	68	*150	25	85	*180	30	110
55	457.9	444.92	*125	25	68	*150	25	85	*180	30	110
56	466.0	453.01	*125	25	68	*150	25	85	*180	30	110
57	474.0	461.08	*125	25	68	*150	25	85	*180	30	110
58	482.1	469.16	*133	25	68	*150	25	85	*180	30	110
59	490.2	477.24	*133	25	68	*150	25	85	*180	30	110
60	498.3	485.23	*133	25	68	*150	25	85	*180	30	110
62	514.5	501.49	*133	25	68	*150	25	85	*180	30	110
64	530.7	517.65	*140	25	68	*160	25	90	*180	30	110
65	538.8	525.73	*140	25	68	*160	25	90	*180	30	110
66	546.8	533.80	*140	25	68	*160	25	90	*180	30	110
68	562.9	549.98	*140	25	68	*160	25	90	*180	30	110
70	579.2	566.15	*140	25	68	*160	25	90	*180	30	110
72	595.4	582.31	*140	25	68	*160	25	90	*180	30	110
75	619.7	606.56	*140	25	68	*160	25	90	*180	30	110
76	627.0	614.64	*140	25	68	*160	25	90	*180	30	110
78	643.3	630.81	*140	25	68	*160	25	90	*180	30	110
80	660.0	646.97	*140	25	68	*160	25	90	*180	30	110
85	699.9	687.39	*140	25	78	*160	25	90	*180	30	110
90	740.3	727.80	*140	25	78	*160	25	90	*180	30	110
95	781.1	768.22	*140	25	78	*160	25	90	*180	30	110
100	821.1	808.64	*140	25	78	*160	25	90	*180	30	110
110	902.0	889.48	*140	25	78	*160	25	90	*180	30	110
114	934.3	921.81	*140	25	78	*160	25	90	*180	30	110
120	982.8	970.32	*140	25	78	*160	25	90	*180	30	110
125	1023.3	1010.73	*140	25	78	*160	25	90	*180	30	110

SPROCKETS 1" X17.02mm"

For chain Acc. to DIN 8187
ISO/R 606

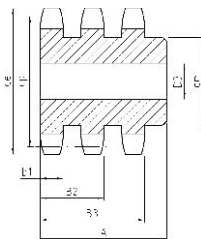
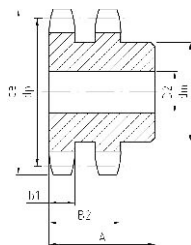
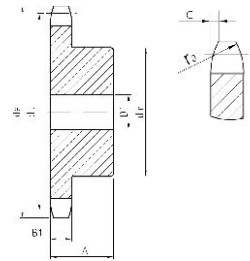

SPROCKETS mm

Tooth radius r _s	26
Radius width C	2.5
Tooth width B ₁	16.2
Tooth width b ₁	15.8
Tooth width B ₂	47.7
Tooth width B ₃	79.6

CHAIN mm

Pitch	25.4
Internal width	17.02
Roller	15.88

Material: C 45
***Weld on hub**

16A-1-2-3 | Platewheels

Z	d _e	d _p	S	D	T
			D ₁	D ₂	D ₃
8	77.0	66.37	12	16	16
9	85.0	74.27	12	16	16
10	93.0	82.19	12	16	16
11	101.5	90.14	16	20	20
12	109.0	98.14	16	20	20
13	117.0	106.12	16	20	20
14	125.0	114.15	16	20	20
15	133.0	122.17	16	20	20
16	141.0	130.20	20	20	25
17	149.0	138.22	20	20	25
18	157.0	146.28	20	20	25
19	165.2	154.33	20	20	25
20	173.2	162.38	20	20	25
21	181.2	170.43	20	25	25
22	189.3	178.48	20	25	25
23	197.5	186.53	20	25	25
24	205.5	194.59	20	25	25
25	213.5	202.66	20	25	25
26	221.6	210.72	20	25	30
27	229.6	218.79	20	25	30
28	237.7	226.85	20	25	30
29	245.8	234.92	20	25	30
30	254.0	243.00	20	25	30
31	262.0	251.08	25	25	30
32	270.0	259.13	25	25	30
33	278.5	267.21	25	25	30
34	287.0	275.28	25	25	30
35	296.2	283.36	25	25	30
36	304.6	291.44	25	25	30
37	312.6	299.51	25	25	30
38	320.7	307.59	25	25	30
39	328.8	315.67	25	25	30
40	336.9	323.75	25	25	30
41	345.0	331.81	25	25	30
42	353.0	339.89	25	25	30
43	361.1	347.97	25	25	30
44	369.1	356.05	25	25	30
45	377.1	364.12	25	25	30
46	385.2	372.20	25	25	30
47	393.2	380.28	25	25	30
48	401.3	388.36	25	25	30
49	409.3	396.44	25	25	30
50	417.4	404.52	25	25	30
51	425.5	412.60	30	30	40
52	433.6	420.68	30	30	40
53	441.7	428.76	30	30	40
54	448.3	436.84	30	30	40
55	457.9	444.92	30	30	40
56	466.0	453.01	30	30	40
57	474.0	461.08	30	30	40
58	482.1	469.16	30	30	40
59	490.2	477.24	30	30	40
60	498.3	485.33	30	30	40
62	514.5	501.49	30	30	40
64	530.7	517.65	30	30	40
65	538.8	525.73	30	30	40
66	546.8	533.80	30	30	40
68	562.9	549.98	30	30	40
70	579.2	566.15	30	30	40
72	595.4	582.31	30	30	40
75	619.7	606.56	30	30	40
76	627.0	614.64	30	30	40
78	643.3	630.81	30	30	40
80	660.0	646.97	30	30	40
85	699.9	687.39	30	30	40
90	740.3	727.80	30	30	40
95	781.1	768.22	30	30	40
100	821.1	808.64	30	30	40
110	902.0	889.48	30	30	40
114	934.3	921.81	30	40	40
120	982.8	970.32	30	40	40
125	1023.3	1010.73	30	40	40

PLATEWHEELS 1" X17.02"

For chain Acc. to DIN 8187
ISO/R 606

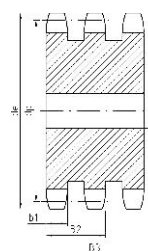
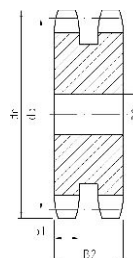
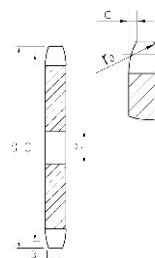

PLATEWHEELS mm

Tooth radius r ₃	26
Radius width C	2.5
Tooth width B ₁	16.2
Tooth width b ₁	15.8
Tooth width B ₂	47.7
Tooth width B ₃	79.6

CHAIN mm

Pitch	25.4
Internal width	17.02
Roller	15.88

20B-1-2-3 | Sprockets



Z	d _e	d _p	SIMPLEX			DUPLEX			TRIPLEX		
			d _m	D ₁	A	d _m	D ₂	A	d _m	D ₃	A
8	98.1	82.96	53	20	40	53	20	75	53	20	110
9	108.0	92.84	63	20	40	63	20	75	63	20	110
10	117.9	102.74	70	20	40	70	20	75	70	20	110
11	127.8	112.68	77	20	45	80	20	80	80	20	115
12	137.8	122.68	88	20	45	90	20	80	90	20	115
13	147.8	132.65	98	20	45	100	20	80	100	20	115
14	157.8	142.68	108	20	45	110	20	80	110	20	115
15	167.9	152.72	118	20	45	120	20	80	120	20	115
16	177.9	162.75	120	20	50	120	25	80	120	25	115
17	187.9	172.78	120	25	50	120	25	80	120	25	115
18	198.0	182.85	120	25	50	*120	25	80	*120	25	115
19	208.1	192.91	120	25	50	*120	25	80	*120	25	115
20	218.1	202.98	120	25	50	*120	25	80	*120	25	115
21	228.2	213.04	140	25	55	*140	25	80	*140	25	115
22	238.3	223.11	140	25	55	*140	25	80	*140	25	115
23	248.3	233.17	140	25	55	*140	25	80	*140	25	115
24	258.4	243.23	140	25	55	*140	25	80	*140	25	115
25	268.5	253.33	140	25	55	*140	25	80	*140	25	115
26	278.6	263.40	*150	25	55	*150	25	80	*150	25	115
27	288.6	273.49	*150	25	55	*150	25	80	*150	25	115
28	298.7	283.56	*150	25	55	*150	25	80	*150	25	115
29	308.8	293.65	*150	25	55	*150	25	80	*150	25	115
30	318.9	303.75	*150	25	55	*150	25	80	*150	25	115
31	329.0	313.85	*150	25	55	*150	25	80	*150	30	115
32	339.1	323.91	*150	25	55	*150	25	80	*150	30	115
33	349.2	334.01	*150	25	55	*150	25	80	*150	30	115
34	359.3	344.10	*150	25	55	*150	25	80	*150	30	115
35	369.4	354.20	*150	25	55	*150	25	80	*150	30	115
36	379.5	364.30	*150	25	55	*150	30	80	*150	30	115
37	389.5	374.39	*150	25	55	*150	30	80	*150	30	115
38	399.6	384.49	*150	25	55	*150	30	80	*150	30	115
39	409.7	394.59	*150	25	55	*150	30	80	*150	30	115
40	419.8	404.69	*150	25	55	*150	30	80	*150	30	115
41	429.9	414.77	*150	25	70	*160	30	90	*160	30	110
42	440.0	424.86	*150	25	70	*160	30	90	*160	30	110
43	450.1	434.96	*150	25	70	*160	30	90	*160	30	110
44	460.2	445.06	*150	25	70	*160	30	90	*160	30	110
45	470.3	455.17	*150	25	70	*160	30	90	*160	30	110
46	480.4	465.25	*150	25	70	*160	30	90	*160	30	110
47	490.5	475.35	*150	25	70	*160	30	90	*160	30	110
48	500.6	485.45	*150	25	70	*160	30	90	*160	30	110
49	510.7	495.55	*150	25	70	*160	30	90	*160	30	110
50	520.8	505.65	*150	25	70	*160	30	90	*160	30	110
51	530.9	515.75	*150	25	80	*160	30	100	*180	30	123
52	541.0	525.85	*150	25	80	*160	30	100	*180	30	123
53	551.1	535.95	*150	25	80	*160	30	100	*180	30	123
54	561.2	546.05	*150	25	80	*160	30	100	*180	30	123
55	571.3	556.15	*150	25	80	*160	30	100	*180	30	123
56	581.4	566.25	*150	25	80	*160	30	100	*180	30	123
57	591.5	576.35	*150	25	80	*160	30	100	*180	30	123
58	601.6	586.45	*150	25	80	*160	30	100	*180	30	123
59	611.7	596.56	*150	25	80	*160	30	100	*180	30	123
60	621.8	606.66	*150	25	80	*160	30	100	*180	30	123
62	642.0	626.86	*150	25	80	*160	30	100	*180	30	123
64	662.2	647.07	*150	25	80	*160	30	100	*180	30	123
65	672.3	657.17	*150	25	80	*160	30	100	*180	30	123
66	682.4	667.27	*150	25	80	*180	30	100	*200	30	123
68	702.6	687.48	*150	25	80	*180	30	100	*200	30	123
70	722.8	707.68	*150	25	80	*180	30	100	*200	30	123
72	743.1	727.89	*150	25	80	*180	30	100	*200	30	123
75	773.3	758.20	*150	25	80	*180	30	100	*200	30	123
76	783.3	768.32	*150	25	80	*180	30	100	*200	30	123
80	823.9	808.71	*150	25	80	*180	30	100	*200	30	123
85	874.4	859.23	*150	25	90	*180	30	100	*200	30	123
90	924.9	909.76	*150	25	90	*180	30	100	*200	30	123
95	975.2	960.28	*150	25	90	*180	30	100	*200	30	123
100	1026.0	1010.80	*150	25	90	*180	30	100	*200	30	123
114	1167.4	1152.26	*150	25	90	*180	30	100	*200	30	126

SPROCKETS 1" 1/4X3/4"

For chain Acc. to DIN 8187
ISO/R 606

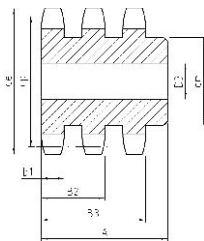
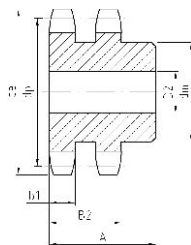
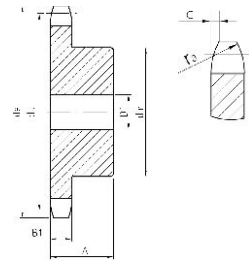

SPROCKETS mm

Tooth radius r ₃	32
Radius width C	3.5
Tooth width B ₁	18.5
Tooth width b ₁	18.2
Tooth width B ₂	54.6
Tooth width B ₃	91

CHAIN mm

Pitch	31.75
Internal width	19.56
Roller	19.05

Material: C 45
*Weld on hub

Sprockets



GOODWILL

20A-1-2-3 | Platewheels

Platewheels

Z	d _e	d _p	S	D	T
			D ₁	D ₂	D ₃
8	98.1	82.96	16	20	20
9	108.0	92.84	16	20	20
10	117.9	102.74	16	20	20
11	127.8	112.68	16	20	20
12	137.8	122.68	20	20	20
13	147.8	132.65	20	20	20
14	157.8	142.68	20	20	20
15	167.9	152.72	20	20	20
16	177.9	162.75	20	25	25
17	187.9	172.78	20	25	25
18	198.0	182.85	20	25	25
19	208.1	192.91	20	25	25
20	218.1	202.98	20	25	25
21	228.2	213.04	25	25	25
22	238.3	223.11	25	25	25
23	248.3	233.17	25	25	25
24	258.4	243.23	25	25	25
25	268.5	253.33	25	25	25
26	278.6	263.40	25	25	25
27	288.6	273.49	25	25	25
28	298.7	283.56	25	25	25
29	308.8	293.65	25	25	25
30	318.9	303.75	25	25	25
31	329.0	313.85	25	25	30
32	339.1	323.91	25	25	30
33	349.2	334.01	25	25	30
34	359.3	344.10	25	25	30
35	369.4	354.20	25	25	30
36	379.5	364.30	25	30	30
37	389.5	374.39	25	30	30
38	399.6	384.49	25	30	30
39	409.7	394.59	25	30	30
40	419.8	404.69	25	30	30
41	429.9	414.77	30	30	30
42	440.0	424.86	30	30	40
43	450.1	434.96	30	30	40
44	460.2	445.06	30	30	40
45	470.3	455.17	30	30	40
46	480.4	465.25	30	30	40
47	490.5	475.35	30	30	40
48	500.6	485.45	30	30	40
49	510.7	495.55	30	30	40
50	520.8	505.65	30	30	40
51	530.9	515.75	30	30	40
52	541.0	525.85	30	30	40
53	551.1	535.95	30	30	40
54	561.2	546.05	30	30	40
55	571.3	556.15	30	30	40
56	581.4	566.25	30	30	40
57	591.5	576.35	30	30	40
58	601.6	586.45	30	30	40
59	611.7	596.56	30	30	40
60	621.8	606.66	30	30	40
62	642.0	626.86	30	30	40
64	662.2	647.07	30	30	40
65	672.3	657.17	30	30	40
66	682.4	667.27	30	30	40
68	702.6	687.48	30	30	40
70	722.8	707.68	30	30	40
72	743.1	727.89	30	30	40
75	773.3	758.20	30	30	40
76	783.5	768.32	30	30	40
80	823.9	808.71	30	30	40
85	874.4	859.23	30	30	40
90	924.9	909.76	30	30	40
95	975.2	960.28	30	30	40
100	1026.0	1010.80	30	30	40
114	1167.4	1152.26	30	40	40

PLATEWHEELS 1" 1/4X3/4"

For chain Acc. to DIN 8187
ISO/R 606

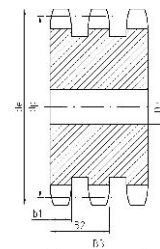
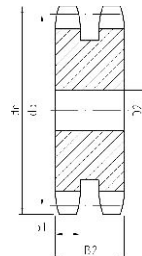
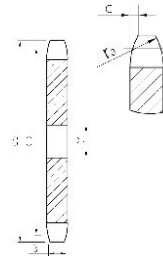

PLATEWHEELS mm

Tooth radius r ₃	32
Radius width C	3.5
Tooth width B ₁	18.5
Tooth width b ₁	18.2
Tooth width B ₂	54.6
Tooth width B ₃	91

CHAIN mm

Pitch	31.75
Internal width	19.56
Roller	19.05

24B-1-2-3 | Sprockets



Z	d _e	d _p	SIMPLEX			DUPLEX			TRIPLEX		
			d _m	D ₁	A	d _m	D ₂	A	d _m	D ₃	A
8	115.0	99.55	58	20	45	58	25	95	58	25	140
9	126.4	111.40	70	20	45	70	25	95	70	25	140
10	138.0	123.29	80	20	45	80	25	95	80	25	140
11	150.0	135.21	90	25	50	90	25	100	90	25	150
12	162.0	147.22	102	25	50	102	25	100	102	25	150
13	174.2	159.18	114	25	50	114	25	100	114	25	150
14	186.2	171.22	128	25	50	128	25	100	128	25	150
15	198.2	183.26	132	25	50	132	25	100	132	25	150
16	210.3	195.30	*136	25	55	*136	25	100	136	25	150
17	222.3	207.34	*136	25	55	*136	25	100	140	25	150
18	234.3	219.42	*150	25	55	*150	25	100	*150	25	150
19	246.5	231.49	*136	25	55	*160	25	100	*160	25	150
20	258.6	243.57	*136	25	55	*160	25	100	*160	25	150
21	270.6	255.65	*150	25	60	*160	25	100	*160	30	150
22	282.7	267.73	*150	25	60	*160	25	100	*160	30	150
23	294.8	279.80	*150	25	60	*160	25	100	*160	30	150
24	306.8	291.88	*150	25	60	*160	25	100	*160	30	150
25	319.0	304.00	*150	25	60	*160	25	100	*160	30	150
26	331.0	316.08	*150	30	60	*160	30	100	*160	30	150
27	343.2	328.19	*150	30	60	*160	30	100	*160	30	150
28	355.2	340.27	*150	30	60	*160	30	100	*160	30	150
29	367.3	352.38	*150	30	60	*160	30	100	*160	30	150
30	379.5	364.50	*150	30	60	*160	30	100	*160	40	150
31	391.6	376.62	*150	30	60	*160	30	100	*160	40	150
32	403.7	388.69	*150	30	60	*160	30	100	*160	40	150
33	415.8	400.81	*150	30	60	*160	30	100	*160	40	150
34	427.8	412.93	*150	30	60	*160	30	100	*160	40	150
35	440.0	425.04	*150	30	60	*160	30	100	*160	40	150
36	452.0	437.16	*150	30	60	*160	30	100	*160	40	150
37	464.2	449.27	*150	30	60	*160	30	100	*160	40	150
38	476.2	461.39	*150	30	60	*160	30	100	*160	40	150
39	488.5	473.50	*150	30	60	*160	30	100	*160	40	150
40	500.6	485.62	*150	30	60	*160	30	100	*160	40	150
41	512.6	497.72	*160	30	90	*180	30	100	*200	40	150
42	524.7	509.83	*160	30	90	*180	30	100	*200	40	150
43	536.8	521.95	*160	30	90	*180	30	100	*200	40	150
44	549.0	534.07	*160	30	90	*180	30	100	*200	40	150
45	561.2	546.19	*160	30	90	*180	30	100	*200	40	150
46	573.3	558.30	*160	30	90	*180	30	100	*200	40	150
47	585.4	570.42	*160	30	90	*180	30	100	*200	40	150
48	597.4	582.54	*160	30	90	*180	30	100	*200	40	150
49	609.5	594.66	*160	30	90	*180	30	100	*200	40	150
50	621.7	606.78	*160	30	90	*180	30	100	*200	40	150
51	633.8	618.90	*160	30	100	*180	30	110	*200	40	150
52	646.0	631.01	*160	30	100	*180	30	110	*200	40	150
53	658.0	643.13	*160	30	100	*180	30	110	*200	40	150
54	670.2	655.28	*160	30	100	*180	30	110	*200	40	150
55	682.3	667.40	*160	30	100	*180	30	110	*200	40	150
56	694.4	679.51	*160	30	100	*180	30	110	*200	40	150
57	706.5	691.63	*160	30	100	*180	30	110	*200	40	150
58	718.6	703.74	*160	30	100	*180	30	110	*200	40	150
59	730.7	715.86	*160	30	100	*180	30	110	*200	40	150
60	742.8	727.97	*160	30	100	*180	30	110	*200	40	150
62	767.2	752.24	*160	30	100	*180	30	110	*200	40	150
64	791.3	776.48	*160	30	100	*200	30	110	*220	40	150
65	803.4	788.59	*160	30	100	*200	30	110	*220	40	150
66	815.6	800.71	*160	30	100	*200	30	120	*220	40	150
68	839.8	824.98	*160	30	100	*200	30	120	*220	40	150
70	864.2	849.21	*160	30	100	*200	30	120	*220	40	150
72	888.4	873.48	*160	30	100	*200	30	120	*220	40	150
75	924.8	909.83	*160	30	100	*200	30	120	*220	40	150
76	936.9	921.98	*160	30	100	*200	30	120	*220	40	150
80	985.4	970.44	*160	30	100	*200	30	120	*220	40	150
85	1046.0	1031.10	*160	30	100	*200	30	120	*220	40	150
90	1167.3	1152.33	*160	30	100	*200	30	120	*220	40	150

SPROCKETS 1" 1/2X1"

For chain Acc. to DIN 8187
ISO/R 606

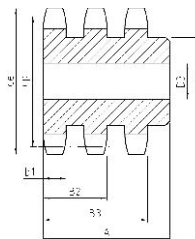
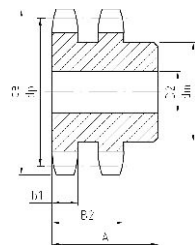
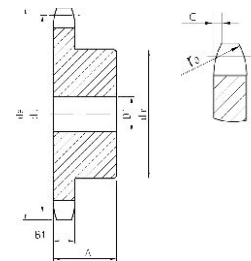

SPROCKETS mm

Tooth radius r ₃	38
Radius width C	4
Tooth width B ₁	24.1
Tooth width b ₁	23.6
Tooth width B ₂	72
Tooth width B ₃	120.3

CHAIN mm

Pitch	38.1
Internal width	25.4
Roller	25.4

Material: C 45
*Weld-on hub



GOODWILL

24A-1-2-3 | Platewheels

Platewheels

PLATEWHEELS 1" 1/2X1"

For chain Acc. to DIN 8187
ISO/R 606

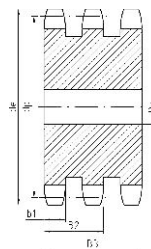
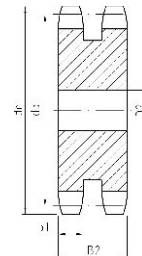
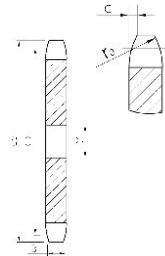

Z	d _e	d _p	S	D	T
			D ₁	D ₂	D ₃
8	115.0	99.55	20	25	25
9	126.4	111.40	20	25	25
10	138.0	123.29	20	25	25
11	150.0	135.21	20	25	25
12	162.0	147.22	20	25	25
13	174.2	159.18	20	25	25
14	186.2	171.22	20	25	25
15	198.2	183.26	20	25	25
16	210.3	195.30	25	25	25
17	222.3	207.34	25	25	25
18	234.3	219.42	25	25	25
19	246.5	231.49	25	25	25
20	258.6	243.57	25	25	25
21	270.6	255.65	25	25	30
22	282.7	267.73	25	25	30
23	294.8	279.80	25	25	30
24	306.8	291.88	25	25	30
25	319.0	304.00	25	25	30
26	331.0	316.08	30	30	30
27	343.2	328.19	30	30	30
28	355.2	340.27	30	30	30
29	367.3	352.38	30	30	30
30	379.5	364.50	30	30	40
31	391.6	376.62	30	30	40
32	403.7	388.69	30	30	40
33	415.8	400.81	30	30	40
34	427.8	412.93	30	30	40
35	440.0	425.04	30	30	40
36	452.0	437.16	30	30	40
37	464.2	449.27	30	30	40
38	476.2	461.39	30	30	40
39	488.5	473.50	30	30	40
40	500.6	485.62	30	30	40
41	512.6	497.72	30	40	40
42	524.7	509.83	30	40	40
43	536.8	521.95	30	40	40
44	549.0	534.07	30	40	40
45	561.2	546.19	30	40	40
46	573.3	558.30	30	40	40
47	585.4	570.42	30	40	40
48	597.4	582.54	30	40	40
49	609.5	594.66	30	40	40
50	621.7	606.78	30	40	40
51	633.8	618.90	30	40	40
52	646.0	631.01	30	40	40
53	658.0	643.13	30	40	40
54	670.2	655.28	30	40	40
55	682.3	667.40	30	40	40
56	694.4	679.51	30	40	40
57	706.5	691.63	30	40	40
58	718.6	703.74	30	40	40
59	730.7	715.86	30	40	40
60	742.8	727.97	30	40	40
62	767.2	752.24	40	40	40
64	791.3	776.48	40	40	40
65	803.4	788.59	40	40	40
66	815.6	800.71	40	40	40
68	839.8	824.98	40	40	40
70	864.2	849.21	40	40	40
72	888.4	873.48	40	40	40
75	924.8	909.83	40	40	40
76	936.9	921.98	40	40	40
80	985.4	970.44	40	40	40
85	1046.0	1031.10	40	40	40
95	1167.3	1152.33	40	40	40

PLATEWHEELS mm

Tooth radius r _s	38
Radius width C	4
Tooth width B ₁	24.1
Tooth width b ₁	23.6
Tooth width B ₂	72
Tooth width B ₃	120.3

CHAIN mm

Pitch	38.1
Internal width	25.4
Roller	25.4

28B-1-2-3 | Sprockets



Z	d _e	d _p	SIMPLEX			DUPLEX			TRIPLEX		
			d _m	D ₁	A	d _m	D ₂	A	d _m	D ₃	A
8	132.0	116.15	74	25	70	74	25	120	74	30	180
9	148.4	129.96	88	25	70	88	25	120	88	30	180
10	162.3	143.85	100	25	70	100	25	120	100	30	180
11	176.3	157.77	112	25	70	112	25	120	112	30	180
12	189.5	171.74	125	25	70	125	25	120	125	30	180
13	204.2	185.75	*125	25	70	*125	25	120	*125	30	180
14	218.2	199.76	*125	25	70	*125	25	120	*125	30	180
15	232.3	213.79	*125	25	70	*145	25	120	*145	30	180
16	246.3	227.84	*160	30	75	*160	30	120	*160	30	180
17	260.3	241.91	*160	30	75	*160	30	120	*160	30	180
18	274.0	255.98	*160	30	75	*160	30	120	*160	30	180
19	289.0	270.06	*160	30	75	*180	30	120	*180	30	180
20	303.0	284.15	*160	30	75	*180	30	120	*180	30	180
21	317.0	298.24	*160	30	75	*180	30	120	*180	30	180
22	331.0	312.34	*160	30	75	*180	30	120	*180	30	180
23	345.0	326.44	*160	30	75	*180	30	120	*180	30	180
24	359.0	340.55	*160	30	75	*180	30	120	*180	30	180
25	373.0	354.66	*160	30	75	*180	30	120	*180	40	180
26	387.0	368.77	*160	30	75	*180	30	120	*180	40	180
27	401.4	382.88	*160	30	75	*180	30	120	*180	40	180
28	416.0	397.00	*160	30	75	*180	30	120	*180	40	180
29	430.0	411.12	*160	30	75	*180	30	120	*180	40	180
30	444.0	425.24	*160	30	75	*180	30	120	*180	40	180
31	458.0	439.37	*180	30	75	*180	30	120	*180	40	180
32	472.0	453.49	*180	30	75	*180	30	120	*180	40	180
33	486.0	467.62	*180	30	75	*180	30	120	*180	40	180
34	500.0	481.75	*180	30	75	*180	30	120	*180	40	180
35	514.0	495.88	*180	30	75	*200	30	120	*200	40	180
36	529.0	510.01	*180	30	75	*200	30	120	*180	40	180
37	543.0	524.14	*180	30	75	*200	30	120	*180	40	180
38	557.0	538.27	*180	30	75	*200	30	120	*200	40	180
39	571.0	552.40	*180	30	75	*200	30	120	*200	40	180
40	585.0	566.54	*180	30	75	*200	30	120	*200	40	180
45	656.0	637.22	*180	30	90	*200	30	120	*200	40	180
50	726.0	707.91	*180	30	90	*200	30	120	*200	40	180
57	825.0	806.89	*180	30	100	*200	30	120	*200	40	180
60	869.0	849.32	*180	30	100	*200	30	130	*200	40	190
76	1095.0	1075.60	*180	30	100	*200	30	130	*200	40	190

SPROCKETS 1" 3/4X1" 1/4

For chain Acc. to DIN 8187
ISO/R 606

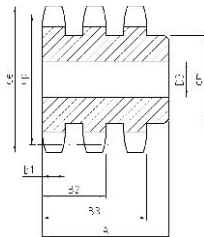
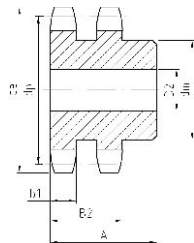
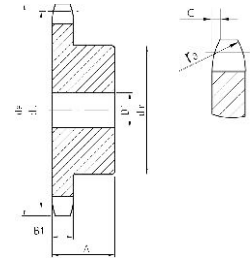

SPROCKETS mm

Tooth radius r ₃	44
Radius width C	5
Tooth width B ₁	29.4
Tooth width b ₁	28.8
Tooth width B ₂	88.4
Tooth width B ₃	148

CHAIN mm

Pitch	44.45
Internal width	30.99
Roller	27.94

Material: C 45
*Weld-on hub

28A-1-2-3 | Platewheels



Z	d _e	d _p	S	D	T
			D ₁	D ₂	D ₃
8	132.0	116.15	20	25	25
9	148.4	129.96	20	25	25
10	162.3	143.85	20	25	25
11	176.3	157.77	25	25	30
12	189.5	171.74	25	25	30
13	204.2	185.74	25	25	30
14	218.2	199.76	25	25	30
15	232.3	213.79	25	25	30
16	246.3	227.84	30	30	30
17	260.0	241.91	30	30	30
18	274.0	255.98	30	30	30
19	289.0	270.06	30	30	30
20	303.0	284.15	30	30	30
21	317.0	298.24	30	30	30
22	331.0	312.34	30	30	30
23	345.0	326.44	30	30	30
24	359.0	340.55	30	30	30
25	373.0	354.66	30	30	40
26	387.0	368.77	30	30	40
27	401.4	382.88	30	30	40
28	416.0	397.00	30	30	40
29	430.0	411.12	30	30	40
30	444.0	425.24	30	30	40
31	458.0	439.37	30	30	40
32	472.0	453.49	30	30	40
33	486.0	467.62	30	30	40
34	500.0	481.75	30	30	40
35	514.0	495.88	30	30	40
36	529.0	510.01	30	30	40
37	543.0	524.14	30	30	40
38	557.0	538.27	30	30	40
39	571.0	552.40	30	30	40
40	585.0	566.54	30	30	40
45	656.0	637.22	30	30	40
50	726.0	707.91	30	30	40
57	825.0	806.89	40	40	40
60	869.0	849.32	40	40	40
76	1095.0	1075.60	40	40	40

PLATEWHEELS 1" 3/4X1" 1/4

For chain Acc. to DIN 8187
ISO/R 606

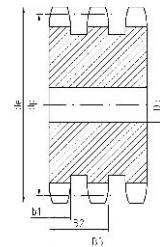
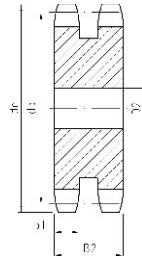
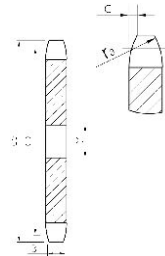

PLATEWHEELS mm

Tooth radius r ₃	44
Radius width C	5
Tooth width B ₁	29.4
Tooth width b ₁	28.8
Tooth width B ₂	88.4
Tooth width B ₃	148

CHAIN mm

Pitch	44.45
Internal width	30.99
Roller	27.94

32B-1-2-3 | Sprockets

Z	d _e	d _p	SIMPLEX			DUPLEX			TRIPLEX		
			d _m	D ₁	A	d _m	D ₂	A	d _m	D ₃	A
8	153.2	132.69	82	25	80	82	30	120	82	30	180
9	169.0	148.54	88	25	80	88	30	120	88	30	180
10	185.0	164.54	104	25	80	104	30	120	104	30	180
11	200.8	180.34	120	30	80	120	30	120	120	30	180
12	216.8	196.29	133	30	80	*133	30	120	*133	30	180
13	232.8	212.29	*145	30	80	*145	30	120	*145	30	180
14	248.8	228.29	*145	30	80	*145	30	120	*145	30	180
15	264.8	244.30	*145	30	80	*160	30	120	*160	30	180
16	280.9	260.40	*160	30	90	*160	30	120	*160	30	180
17	296.9	276.40	*160	30	90	*180	30	120	*180	30	180
18	313.0	292.55	*160	30	90	*180	30	120	*180	30	180
19	329.1	308.66	*160	30	90	*200	30	120	*200	30	180
20	345.2	324.71	*180	30	90	*200	30	120	*200	30	180
21	361.3	340.82	*180	30	90	*200	30	120	*200	40	180
22	377.5	356.98	*180	30	90	*200	30	120	*200	40	180
23	393.6	373.08	*180	30	90	*200	30	120	*200	40	180
24	409.7	389.18	*180	30	90	*200	30	120	*200	40	180
25	425.8	405.33	*180	30	90	*200	30	120	*200	40	180
26	441.9	421.44	*180	30	90	*200	30	120	*200	40	180
27	458.1	437.59	*180	30	90	*200	30	120	*200	40	180
28	474.2	453.69	*180	30	90	*200	30	120	*200	40	180
29	490.4	469.90	*180	30	90	*200	30	120	*200	40	180
30	506.5	486.00	*180	30	90	*200	30	120	*200	40	180
32	538.8	518.26	*180	30	90	*200	30	120	*200	40	180
35	589.5	566.72	*180	30	90	*200	30	120	*200	40	180
38	635.5	615.14	*180	30	90	*200	30	120	*200	40	180
40	670.3	647.49	*180	30	90	*200	30	120	*200	40	180
45	751.0	728.25	*180	30	100	*200	30	120	*200	40	180
50	831.8	809.04	*180	30	100	*200	30	120	*200	40	180
57	945.0	922.16	*180	30	100	*220	30	120	*200	40	180
60	993.4	970.65	*200	30	110	*220	30	130	*220	40	180
76	1252.0	1229.30	*200	30	110	*220	30	130	*238	40	180

SPROCKETS 2" X1" 1/4

For chain Acc. to DIN 8187
ISO/R 606

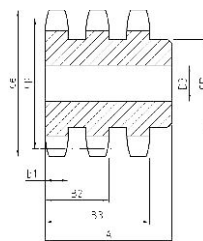
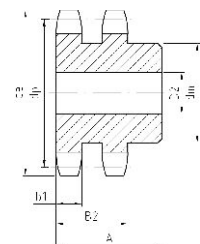
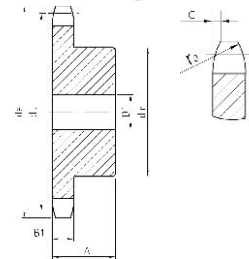

SPROCKETS mm

Tooth radius r ₃	51
Radius width C	6
Tooth width B ₁	29.4
Tooth width b ₁	28.8
Tooth width B ₂	87.4
Tooth width B ₃	146

CHAIN mm

Pitch	50.8
Internal width	30.99
Roller	29.21

Material: C 45
***Weld-on hub**



GOODWILL

Stainless Steel Sprockets

Stainless Steel Sprockets

For Roller Chains DIN8187-ISO/R606

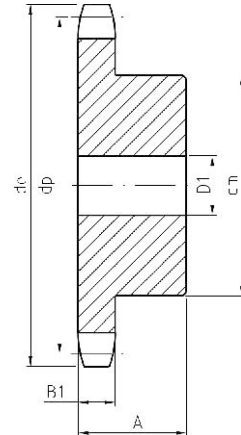

Pitch	Z	12	13	15	16	17	18	19	20	21	23	25	30
06B 3/8" X7/32"	de	-	43.0	49.3	52.3	55.3	58.3	61.3	63.4	68.0	73.5	80.0	94.7
	dp	-	39.79	45.81	48.82	51.83	54.85	57.87	60.89	63.91	69.95	76.00	91.12
	dm	-	28	34	37	40	43	45	46	48	52	57	60
	D ₁	-	10	10	10	10	10	10	10	10	10	12	12
	A	-	25	25	28	28	28	28	28	28	28	28	30
08B 1/2" X5/16"	de	53.0	57.9	65.9	69.9	74.0	78.0	82.0	86.0	90.1	98.1	106.2	126.3
	dp	49.07	53.6	61.09	65.10	69.11	73.14	77.16	81.19	85.22	93.27	101.33	121.50
	dm	33	37	45	50	52	56	60	64	68	70	70	80
	D ₁	10	10	10	12	12	12	12	12	14	14	14	16
	A	28	28	28	28	28	28	28	28	28	28	28	30
10B 5/8" X3/8"	de	-	73.0	83.0	88.0	93.0	98.3	103.3	108.4	113.4	123.4	134.0	158.8
	dp	-	66.32	76.36	81.37	86.39	91.42	96.45	101.49	106.52	116.58	126.66	151.87
	dm	-	47	57	60	60	70	75	75	80	80	80	90
	D ₁	-	12	12	12	12	12	14	14	16	16	16	20
	A	-	30	30	30	30	30	30	30	30	30	30	35
12B 3/4" X7/16"	de	-	87.5	99.8	105.5	111.5	118.0	124.2	129.7	136.0	149.0	160.0	-
	dp	-	79.59	91.63	97.65	103.67	109.71	115.75	121.78	127.82	139.90	152.0	-
	dm	-	58	70	75	80	80	80	80	90	90	90	-
	D ₁	-	16	16	16	16	16	16	16	20	20	20	-
	A	-	35	35	35	35	35	35	35	40	40	40	-
16B 1" X17/02	de	-	117.0	133.0	141.0	149.0	157.0	165.2	173.0	181.2	-	-	-
	dp	-	106.12	122.17	130.2	138.22	146.28	154.33	162.38	170.43	-	-	-
	dm	-	78	92	100	100	100	100	100	110	-	-	-
	D ₁	-	16	16	19	20	20	20	20	20	-	-	-
	A	-	40	40	45	45	45	45	45	50	-	-	-

Material AISI304L



GOODWILL

Cast Iron Sprockets

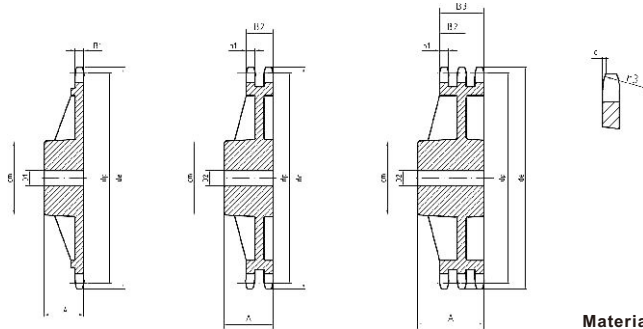

Material:GG22-GG25

Cast Iron Sprockets

3/8 " X7/32 " 06B-1-2-3 Acc.to DIN 8187 ISO/R 606

Z	d _o	d _p	SIMPLEX			DUPLEX			TRIPLEX		
			d _m	D ₁	A	d _m	D _z	A	d _m	D ₃	A
38	119.5	115.35	70	20	32	80	20	40	90	24	56
45	140.7	136.55	70	20	32	80	20	40	90	24	56
57	176.9	172.91	70	20	32	80	20	40	90	24	56
76	234.9	230.49	70	20	32	80	20	40	100	24	56
95	292.5	288.08	80	20	40	90	20	45	100	24	56
114	349.6	345.68	80	20	40	95	20	45	100	24	56
150	459.2	454.82	90	24	45	100	24	50	125	24	60

SPROCKETS		mm
Tooth radius r _s		10
Radius width C		1
Tooth width B ₁		5.3
Tooth width b ₁		5.2
Tooth width B ₂		15.4
Tooth width B ₃		25.6
CHAIN		mm
Pitch		9.525
Internal width		5.72
Roller		6.35

1/2 " X5/16 " 08B-1-2-3 Acc.to DIN 8187 ISO/R 606

Z	d _o	d _p	SIMPLEX			DUPLEX			TRIPLEX		
			d _m	D ₁	A	d _m	D _z	A	d _m	D ₃	A
38	158.6	153.80	70	20	40	90	24	50	100	24	60
45	188.0	182.07	70	20	40	90	24	50	100	24	60
57	236.4	230.54	70	20	40	90	24	50	100	24	60
76	313.3	307.33	80	24	40	100	24	56	100	24	60
95	390.1	384.11	80	24	45	100	24	56	120	24	67
114	466.9	460.90	80	24	45	100	24	63	120	24	67

SPROCKETS		mm
Tooth radius r _s		13
Radius width C		1.3
Tooth width B ₁		7.2
Tooth width b ₁		7
Tooth width B ₂		21
Tooth width B ₃		34.9
CHAIN		mm
Pitch		12.7
Internal width		7.75
Roller		8.51

5/8 " X3/8 " 10B-1-2-3 Acc.to DIN 8187 ISO/R 606

Z	d _o	d _p	SIMPLEX			DUPLEX			TRIPLEX		
			d _m	D ₁	A	d _m	D _z	A	d _m	D ₃	A
38	199.2	192.24	80	20	40	100	30	50	100	32	60
45	235.0	227.58	80	20	40	100	30	50	100	32	60
57	296.0	288.18	90	24	45	100	30	56	100	32	63
76	392.1	384.16	90	24	50	100	30	63	110	35	67
95	488.5	480.14	100	24	56	110	30	63	125	35	70
114	584.1	576.13	100	24	56	125	30	70	125	35	80

SPROCKETS		mm
Tooth radius r _s		16
Radius width C		1.6
Tooth width B ₁		9.1
Tooth width b ₁		9
Tooth width B ₂		25.5
Tooth width B ₃		42.1
CHAIN		mm
Pitch		15.875
Internal width		9.65
Roller		10.16

3/4 " X7/16 " 12B-1-2-3 Acc.to DIN 8187 ISO/R 606

Z	d _o	d _p	SIMPLEX			DUPLEX			TRIPLEX		
			d _m	D ₁	A	d _m	D _z	A	d _m	D ₃	A
38	239.0	230.69	100	24	56	110	30	63	140	30	70
45	282.5	273.10	100	24	56	110	30	63	140	30	70
57	354.0	345.81	100	30	56	120	30	63	140	40	70
76	469.9	460.99	100	30	56	135	30	63	160	40	75
95	585.1	576.17	100	30	65	135	30	70	170	40	82
114	700.6	691.36	100	30	65	135	30	70	170	50	82

SPROCKETS		mm
Tooth radius r _s		19
Radius width C		2
Tooth width B ₁		11.1
Tooth width b ₁		10.8
Tooth width B ₂		30.3
Tooth width B ₃		49.8
CHAIN		mm
Pitch		19.05
Internal width		11.68
Roller		12.07



GOODWILL

Cast Iron Sprockets

For Roller Chinas DIN8187-ISO/R606

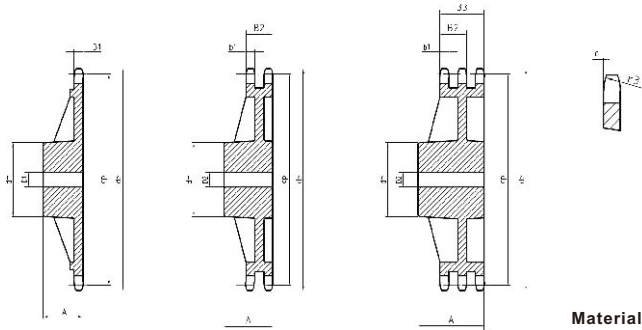

Material:GG22-GG25

1" X17.02mm 06B-1-2-3 Acc.to DIN 8187 ISO/R 606

Z	d _e	d _p	SIMPLEX			DUPLEX			TRIPLEX		
			d _m	D ₁	A	d _m	D ₁₂	A	d _m	D ₃	A
30	254.0	243.00	110	30	65	125	40	75	145	40	90
38	320.0	307.59	110	30	65	140	40	75	160	45	100
45	377.0	364.13	125	30	70	150	40	75	160	45	100
57	474.0	461.08	125	35	70	170	40	90	165	45	100
76	627.0	614.65	140	35	80	175	40	95	200	45	110
95	781.0	768.22	140	40	80	175	45	95	200	50	110
114	933.0	921.81	140	40	80	175	45	95	200	50	115

SPROCKETS

Tooth radius r _s	26
Radius width C	2.5
Tooth width B ₁	16.2
Tooth width b ₁	15.8
Tooth width B ₂	47.7
Tooth width B ₃	79.6

CHAIN:

Pitch	25.4
Internal width	17.02
Roller	15.88

1" 1/4X3/4" 20B-1-2-3 Acc.to DIN 8187 ISO/R 606

Z	d _e	d _p	SIMPLEX			DUPLEX			TRIPLEX		
			d _m	D ₁	A	d _m	D ₁₂	A	d _m	D ₃	A
30	318.9	303.75	115	35	70	130	40	80	160	50	100
38	399.6	384.49	125	35	70	140	45	90	180	56	110
45	470.3	455.17	125	35	70	140	45	90	180	56	110
57	591.5	576.36	135	40	80	160	50	100	180	60	125
76	783.5	768.32	140	40	90	180	50	100	200	60	140

SPROCKETS

Tooth radius r _s	32
Radius width C	3.5
Tooth width B ₁	18.5
Tooth width b ₁	18.2
Tooth width B ₂	54.6
Tooth width B ₃	91

CHAIN:

Pitch	31.75
Internal width	19.56
Roller	19.05

1" 1/2X1" 24B-1-2-3 Acc.to DIN 8187 ISO/R 606

Z	d _e	d _p	SIMPLEX			DUPLEX			TRIPLEX		
			d _m	D ₁	A	d _m	D ₁₂	A	d _m	D ₃	A
30	379.5	364.50	130	40	85	160	40	95	180	60	150
38	476.2	461.39	140	45	90	180	45	100	200	60	150
45	561.2	546.20	140	45	90	180	45	100	200	60	150
57	706.5	691.63	160	45	100	200	55	110	200	70	150
76	936.9	921.98	170	45	100	220	55	120	250	70	150

SPROCKETS

Tooth radius r _s	38
Radius width C	4
Tooth width B ₁	24.1
Tooth width b ₁	23.6
Tooth width B ₂	72
Tooth width B ₃	120.3

CHAIN:

Pitch	38.1
Internal width	25.4
Roller	25.4

Duplex Platewheels For Two Single Roller Chains



For Roller Chains DIN8187-ISO/R606

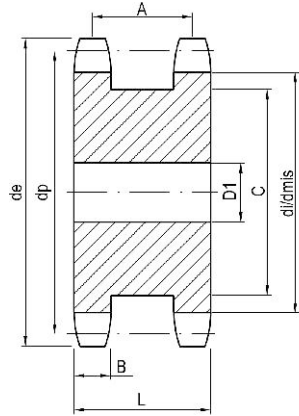

Type	Z	d _e	d _p	d _i	d _{mis}	D	A	B h14	C _{max}	L	
3/8" X 7/32" R6.35	13	43	39.80	33.45	33.16	10	20.3	5.3	28	25.5	
	15	49.3	45.81	39.46	39.21	10	20.3	5.3	34	25.5	
	17	55.3	51.84	45.49	45.27	12	20.3	5.3	40	25.5	
	19	61.3	57.87	51.52	51.32	12	20.3	5.3	46	25.5	
	21	68	63.91	57.56	57.38	15	20.3	5.3	52	25.5	
06B-1	23	73.5	69.95	63.60	63.44	15	20.3	5.3	59	25.5	
	25	80	76.00	69.65	69.50	15	20.3	5.3	65	25.5	
	1/2" X 5/16" R8.51	13	57.4	53.07	44.56	44.17	10	24.8	7.2	37	32
		15	65.5	61.08	52.57	52.24	10	24.8	7.2	45	32
17		73.6	69.12	60.61	60.31	12	24.8	7.2	53	32	
19		81.7	77.16	68.65	68.39	12	24.8	7.2	62	32	
21		89.7	85.21	76.71	76.46	15	24.8	7.2	70	32	
23		98.2	93.27	84.76	84.54	15	24.8	7.2	78	32	
08B-1	25	105.8	101.33	92.82	92.62	15	24.8	7.2	86	32	
	5/8" X 3/8" R10.16	13	73	66.33	56.17	55.69	15	27.9	9.1	48	37
15		83	76.35	66.19	65.78	15	27.9	9.1	58	37	
17		93	86.39	76.23	75.87	15	27.9	9.1	68	37	
19		103.3	96.45	86.29	85.96	19	27.9	9.1	79	37	
21		113.4	106.51	96.35	96.06	19	27.9	9.1	89	37	
23		123.4	116.59	106.43	106.15	19	27.9	9.1	99	37	
10B-1	25	134	126.66	116.50	116.25	19	27.9	9.1	109	37	
	3/4" X 7/16" R12.07	13	87.5	79.60	67.53	66.95	20	33.9	11.1	59	45
15		99.8	91.63	79.56	79.05	20	33.9	11.1	71	45	
17		111.5	103.67	91.60	91.18	20	33.9	11.1	83	45	
19		124.2	115.74	103.67	103.27	20	33.9	11.1	95	45	
21		136	127.82	115.75	115.39	24	33.9	11.1	107	45	
23		149	139.90	127.83	127.51	24	33.9	11.1	119	45	
12B-1	25	160	151.99	139.92	139.62	24	33.9	11.1	131	45	
	1" X 17.02 R15.88	13	117	106.14	90.26	89.48	24	47.8	16.2	78	64
15		133	122.17	106.29	105.62	24	47.8	16.2	95	64	
17		149	138.23	122.35	121.76	24	47.8	16.2	111	64	
19		165.2	154.32	138.44	137.91	24	47.8	16.2	127	64	
21		181.2	170.42	154.54	154.06	24	47.8	16.2	143	64	
16B-1											

ASA35/40 | ASA Sprockets & Platewheels



SPROCKETS			SIMPLEX			DUPLEX		
Z	d _e	d _p	d _m	D ₂	A	d _m	D ₃	A
10	35.70	30.82	20	8	20			
11	38.69	33.80	22	8	25			
12	41.68	36.80	25	8	25			
13	44.68	39.80	28	8	25	28	10	25
14	47.68	42.80	31	8	25	31	10	25
15	50.69	45.81	34	8	25	34	10	25
16	53.70	48.82	37	10	28	37	12	30
17	56.72	51.83	38	10	28	40	12	30
18	59.73	54.85	38	10	28	43	12	30
19	62.75	57.87	45	10	28	46	12	30
20	65.77	60.89	46	10	28	49	12	30
21	68.79	63.91	46	10	28	52	12	30
22	71.81	66.93	50	12	28	55	12	30
23	74.83	69.95	52	12	28	58	12	30
24	77.85	72.97	52	12	28	61	12	30
25	80.88	76.00	57	12	28	64	12	30
26	83.90	79.02	58	12	28	67	12	30
27	86.93	82.04	58	12	28	70	12	30
28	89.95	85.07	60	12	28	73	12	30
30	96.00	91.12	60	12	28			
PLATEWHEELS			S	D	T			
Z	d _e	d _p	D ₁	D ₂	D ₃			
30	96.00	91.12		12				
32	102.06	97.17	12					
36	114.17	109.29	12					
38	120.22	115.34	12	14				
40	126.28	121.40	12					
45	141.43	136.55	16	16				
48	150.52	145.64	16					
57	177.79	172.91	16	16				
76	235.37	230.49	20	20				

PITCH 3/8" X3/16

For Chain
Acc. to DIN 8188 ASA 35
ISO/R 606

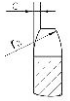

SPROCKETS & PLATEWHEELS mm

Tooth radius r ₃	10
Radius width C	1.2
Tooth width B ₁	4.4
Tooth width b ₁	4.3
Tooth width B ₂	14.4
Tooth width B ₂	24.5

CHAIN mm

Pitch	9.525
Internal width	4.77
Roller	5.08
Material: C45	

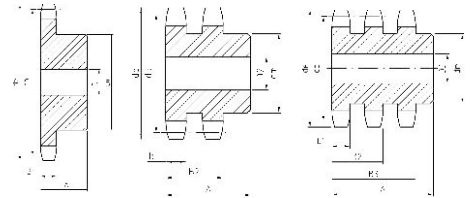

SPROCKETS			SIMPLEX			DUPLEX			TRIPLEX		
Z	d _e	d _p	d _m	D ₁	A	d _m	D ₂	A	d _m	D ₃	A
10	47.66	41.10	26	10	25						
11	51.64	45.08	29	10	25						
12	55.63	49.07	33	10	28						
13	59.63	53.07	35	10	28	38	12	35	35	14	50
14	63.63	57.07	41	10	28	42	12	35	42	14	50
15	67.64	61.08	45	10	28	46	12	35	46	14	50
16	71.66	65.10	48	10	28	50	14	35	50	16	50
17	75.69	69.12	48	10	28	54	14	35	54	16	50
18	79.73	73.14	56	12	28	58	14	35	58	16	50
19	83.72	77.16	60	12	28	62	14	35	62	16	50
20	87.74	81.18	60	12	28	66	14	35	66	16	50
21	91.77	85.21	65	12	28	70	16	40	70	20	55
22	95.80	89.24	65	12	28	70	16	40	70	20	55
23	99.83	93.27	65	12	28	70	16	40	70	20	55
24	103.86	97.30	70	14	28	75	16	40	75	20	55
25	107.89	101.33	70	14	28	80	16	40	80	20	55
26	111.92	105.36	70	14	28	85	16	40	85	20	55
27	115.96	109.40	70	16	30	85	16	40	85	20	55
28	119.99	113.43	70	16	30	90	16	40	90	20	55
30	128.06	121.50	80	16	30	100	16	40			
32	136.13	129.57	80	16	30						
35	148.24	141.68	90	16	30						
36	152.28	145.72	90	16	30						
38	160.35	153.79	90	16	35						
40	168.43	161.87	90	16	35						
PLATEWHEELS			S	D	T						
Z	d _e	d _p	D ₁	D ₂	D ₃						
30	128.06	121.50			20						
32	136.13	129.57		16							
38	160.35	153.79		20	25						
40	168.43	161.87		20							
42	176.50	169.94	20								
45	188.62	182.06	20	20	25						
48	200.74	194.18	20								
57	237.10	230.54	20	25	25						
76	313.88	307.32	25	25	25						
95	390.67	384.11		25							

PITCH 1/2" X5/16

For Chain
Acc. to DIN 8188 ASA 40
ISO/R 606

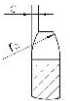

SPROCKETS & PLATEWHEELS mm

Tooth radius r ₃	13.5
Radius width C	1.6
Tooth width B ₁	7.4
Tooth width b ₁	7.2
Tooth width B ₂	21.6
Tooth width B ₃	36

CHAIN mm

Pitch	12.7
Internal width	7.94
Roller	7.94
Material: C45	

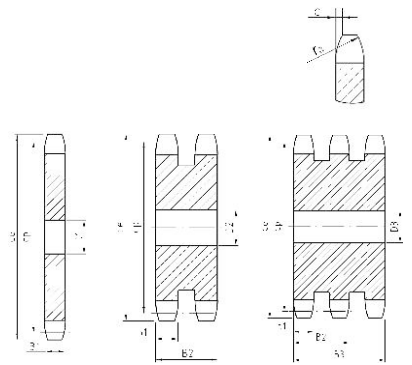

SPROCKETS			SIMPLEX			DUPLEX			TRIPLEX		
Z	d _e	d _p	d _m	D ₁	A	d _m	D ₂	A	d _m	D ₃	A
8	47.0	41.48	25	10	25						
9	52.6	46.42	30	10	25						
10	57.5	51.37	35	10	25						
11	63.0	56.34	37	12	30						
12	68.0	61.34	42	12	30				44	16	55
13	73.0	66.32	47	12	30	49	14	40	49	16	55
14	78.0	71.34	52	12	30	54	14	40	54	16	55
15	83.0	76.36	57	12	30	59	14	40	59	16	55
16	88.0	81.37	60	12	30	64	16	45	64	16	60
17	93.0	86.39	60	12	30	69	16	45	69	16	60
18	98.3	91.42	70	14	30	74	16	45	74	16	60
19	103.3	96.45	70	14	30	79	16	45	79	16	60
20	108.4	101.49	75	14	30	84	16	45	84	16	60
21	113.4	106.52	75	16	30	85	16	45	85	20	60
22	118.0	111.55	80	16	30	90	16	45	90	20	60
23	123.4	116.58	80	16	30	95	16	45	95	20	60
24	128.3	121.62	80	16	30	100	16	45	100	20	60
25	134.0	126.66	80	16	30	105	16	45	105	20	60
26	139.0	131.70	85	20	35				110	20	60
27	144.0	136.75	85	20	35				110	20	60
28	148.7	141.78	90	20	35				115	20	60
29	153.8	146.83	90	20	35						
30	158.8	151.87	90	20	35						
31	163.9	156.92	95	20	35						
32	168.9	161.95	95	20	35						
33	174.5	167.00	95	20	35						
34	179.0	172.05	95	20	35						
35	184.1	177.10	95	20	35						
36	189.1	182.15	100	20	35						
37	194.2	187.20	100	20	35						
38	199.2	192.24	100	20	35						
39	204.2	197.29	100	20	35						
40	209.3	202.34	100	20	35						

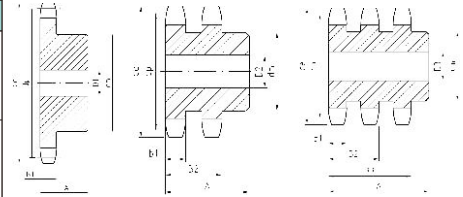

PITCH 5/8" X3/8"

For Chain
Acc. to DIN 8188 ASA 50
ISO/R 606

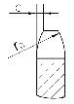

SPROCKETS mm

Tooth radius r_s 17
Radius width C 2
Tooth width B₁ 9
Tooth width b₁ 8.8
Tooth width B₂ 26.9
Tooth width B₃ 45

CHAIN mm

Pitch 15.875
Internal width 9.52
Roller 10.16
Material: C45

PLATEWHEELS			S	D	T	Z	d _e	d _p	S	D	T
Z	d _e	d _p	D ₁	D ₂	D ₃				D ₁	D ₂	D ₃
8	47.0	41.48	10			44	230.0	222.53	20		
9	52.6	46.42	10			45	235.0	227.58	20	20	25
10	57.5	51.37	10			48	240.1	232.63	20		
11	63.0	56.34	10			47	245.1	237.68	20		
12	68.0	61.34	10			48	250.2	242.73	20		
13	73.0	66.32	10			49	255.2	247.78	20		
14	78.0	71.34	10			50	260.3	252.82	20		
15	83.0	76.36	10			51	265.3	257.87	20		
16	88.0	81.37	12			52	270.4	262.92	20		
17	93.0	86.38	12			53	275.4	267.97	20		
18	98.3	91.42	12			54	280.5	273.03	20		
19	103.3	96.45	12			55	285.5	278.08	20		
20	108.4	101.49	12			56	290.6	283.13	25		
21	113.4	106.52	12			57	296.0	288.18	25	25	25
22	118.0	111.55	12			58	300.7	293.23	25		
23	123.5	116.58	12			59	305.7	298.27	25		
24	128.3	121.62	12			60	310.8	303.32	25		
25	134.0	126.66	12			62	321.4	313.43	25		
26	139.0	131.70	16			64	331.5	323.53	25		
27	144.0	136.75	16			65	336.5	328.58	25		
28	148.7	141.78	16			66	341.6	333.63	25		
29	153.8	146.83	16			68	351.7	343.74	25		
30	158.8	151.87	16	20	20	70	361.8	353.84	25		
31	163.9	156.92	16			72	371.9	363.95	25		
32	168.9	161.95	16			75	381.9	379.09	25		
33	174.5	167.00	16			76	392.1	384.16	25	25	30
34	179.0	172.05	16			78	402.2	394.25	25		
35	184.1	177.10	16			80	412.3	404.35	25		
36	189.1	182.15	20			85	437.6	429.62	30		
37	194.2	187.20	20			90	462.8	454.88	30		
38	199.2	192.24	20	20	25	95	488.5	480.14	30	30	
39	204.2	197.29	20			100	513.4	505.39	30		
40	209.3	202.34	20			110	563.9	555.92	30		
41	214.8	207.39	20			114	584.1	576.13	30		
42	219.9	212.44	20			120	614.4	606.45	30		
43	224.9	217.49	20			125	639.7	631.51	30		

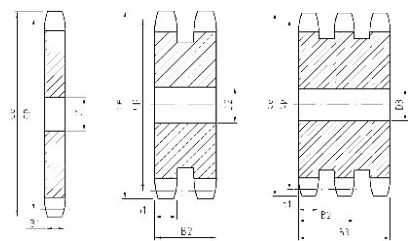

PITCH 5/8" X3/8"

For Chain
Acc. to DIN 8188 ASA 50
ISO/R 606

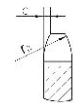

PLATEWHEELS mm

Tooth radius r_s 17
Radius width C 2
Tooth width B₁ 9
Tooth width b₁ 8.8
Tooth width B₂ 26.9
Tooth width B₃ 45

CHAIN mm

Pitch 15.875
Internal width 9.52
Roller 10.16

SPROCKETS			SIMPLEX			DUPLEX			TRIPLEX		
Z	d _e	d _p	d _m	D ₁	A	d _m	D ₂	A	d _m	D ₃	A
10	71.54	61.64	42	12	30	42	12	45			
11	77.51	67.61	45	12	30	47	16	50			
12	83.49	73.61	45	12	30	53	16	50	53	20	70
13	89.49	79.59	58	14	35	59	16	50	59	20	70
14	95.50	85.61	60	14	35	65	16	50	65	20	70
15	101.52	91.63	60	14	35	71	16	50	71	20	70
16	107.54	97.65	75	16	35	77	20	50	77	20	70
17	113.56	103.67	75	16	35	83	20	50	83	20	70
18	119.59	109.71	75	16	35	89	20	50	89	20	70
19	125.63	115.75	80	16	35	95	20	50	95	20	70
20	131.67	121.78	80	16	35	100	20	50	100	20	70
21	137.71	127.82	80	16	35	100	20	50	100	20	70
22	143.75	133.86	90	20	40	100	20	50	100	20	70
23	149.79	139.90	90	20	40	110	20	50	110	20	70
24	155.84	145.94	90	20	40	110	20	50	110	20	70
25	161.88	152.00	90	20	40	120	20	50	120	20	70
26	167.93	158.04	90	20	40	120	20	50			
27	173.98	164.09	90	20	40	120	20	50			
28	180.03	170.13	95	20	40	120	20	50			
30	192.14	182.25	95	20	40	120	20	50			

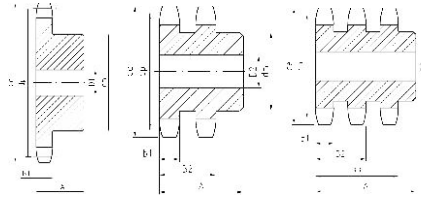

PITCH 3/4" X1/2"

For Chain
Acc. to DIN 8188 **ASA 60**
ISO/R 606

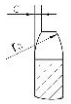

SPROCKETS mm

Tooth radius r ₃	20
Radius width C	2.4
Tooth width B ₁	12.0
Tooth width b ₁	11.8
Tooth width B ₂	34.6
Tooth width B ₃	57.4

CHAIN mm

Pitch	19.05
Internal width	12.7
Roller	11.91
Material: C45	

PLATEWHEELS			S	D	T
Z	d _e	d _p	D ₁	D ₂	D ₃
30	192.14	182.25			20
32	204.24	194.35		20	
38	240.58	230.69	20	25	25
40	252.69	242.80	20	25	
45	282.98	273.09	25	25	25
48	301.16	291.27	25		
57	355.70	345.81	25	25	30
76	470.87	460.98	30	30	30
95	586.06	576.17		30	

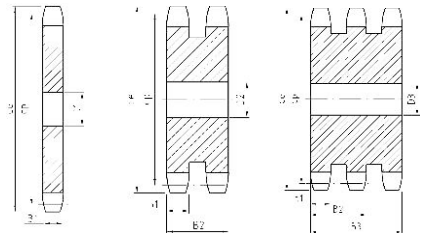

PITCH 3/4" X1/2"

For Chain
Acc. to DIN 8188 **ASA 60**
ISO/R 606

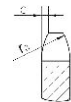

PLATEWHEELS mm

Tooth radius r ₃	20
Radius width C	2.4
Tooth width B ₁	12.0
Tooth width b ₁	11.8
Tooth width B ₂	34.6
Tooth width B ₃	57.4

CHAIN mm

Pitch	19.05
Internal width	12.7
Roller	11.91

SPROCKETS			SIMPLEX			DUPLEX			TRIPLEX		
Z	d _e	d _p	d _m	D ₁	A	d _m	D ₂	A	d _m	D ₃	A
8	79.49	66.37	42	16	35						
9	87.38	74.27	50	16	35						
10	95.32	82.19	55	16	35						
11	103.28	90.14	61	16	40						
12	111.26	98.14	69	16	40	72	20	70	72	25	100
13	119.26	106.12	78	16	40	78	20	70	78	25	100
14	127.27	114.15	84	16	40	86	20	70	86	25	100
15	135.29	122.17	92	16	40	94	20	70	94	25	100
16	143.32	130.20	100	20	45	102	20	70	102	30	100
17	151.35	138.22	100	20	45	110	20	70	110	30	100
18	159.39	148.28	100	20	45	118	20	70	118	30	100
19	167.44	154.33	100	20	45	126	20	70	126	30	100
20	175.49	162.38	100	20	45	130	20	70	130	30	100
21	183.54	170.43	110	20	50	130	25	70			
22	191.60	178.48	110	20	50						
23	199.66	186.53	110	20	50						
24	207.72	194.59	110	20	50						
25	215.78	202.66	110	20	50						
26	223.84	210.72	120	20	50						
27	231.91	218.79	120	20	50						
28	239.98	226.85	120	20	50						
29	248.05	234.92	120	20	50						
30	256.12	243.00	120	20	50						

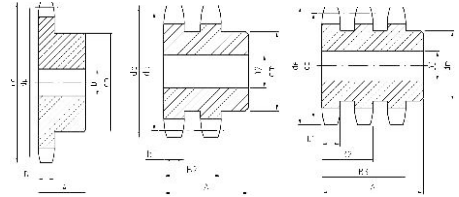

PITCH 1" X5/8"

For Chain
Acc. to DIN 8188 **ASA 80**
ISO/R 606

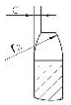

SPROCKETS

	mm
Tooth radius r ₃	27
Radius width C	3.2
Tooth width B ₁	15.0
Tooth width b ₁	14.7
Tooth width B ₂	44.0
Tooth width B ₃	73.3

CHAIN

	mm
Pitch	25.4
Internal width	15.88
Roller	15.88
Material: C45	

PLATEWHEELS			S	D	T
Z	d _e	d _p	D ₁	D ₂	D ₃
10	95.32	82.19	15		
11	103.28	90.14	15		
12	111.26	98.14	15		
13	119.26	106.12	15		
14	127.27	114.15	15		
15	135.29	122.17	15		
16	143.32	130.20	19		
17	151.35	138.22	19		
18	159.39	146.28	19		
19	167.44	154.33	19		
20	175.49	162.38	19		
21	183.54	170.43	20		
22	191.60	178.48	20		
23	199.66	186.53	20		
24	207.72	194.59	20		
25	215.78	202.56	20	25	30
26	223.84	210.72	20		
27	231.91	218.79	20		
28	239.98	226.85	20	25	30
30	256.12	243.00	25		
32	272.26	259.13	25		
35	296.48	283.36	25		
38	320.70	307.59	25	25	30
45	377.24	364.12	25	25	30
50	417.64	404.52	25		
57	474.20	461.08	25	25	40
76	627.80	614.64	25	25	40

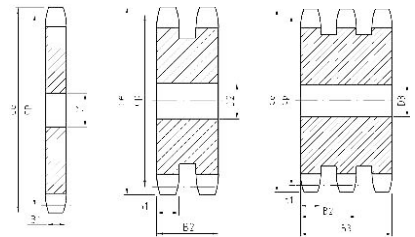

PITCH 1" X5/8"

For Chain
Acc. to DIN 8188 **ASA 80**
ISO/R 606

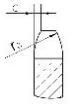

PLATEWHEELS

	mm
Tooth radius r ₃	27
Radius width C	3.2
Tooth width B ₁	15.0
Tooth width b ₁	14.7
Tooth width B ₂	44.0
Tooth width B ₃	73.3

CHAIN

	mm
Pitch	25.4
Internal width	15.88
Roller	15.88

SPROCKETS			SIMPLEX			DUPLEX		
Z	d _e	d _p	d _m	D ₁	A	d _m	D ₂	A
8	98.1	82.96	53	20	40			
9	108.0	92.84	63	20	40			
10	117.9	102.74	70	20	40			
11	127.8	112.68	77	20	45			
12	137.8	122.68	88	20	45	90	20	80
13	147.8	132.65	98	20	45	100	20	80
14	157.8	142.68	108	20	45	110	20	80
15	167.9	152.72	118	20	45	120	20	80
16	177.9	162.75	120	25	50	120	25	80
17	187.9	172.78	120	25	50	120	25	80
18	198.0	182.85	120	25	50			
19	208.1	192.91	120	25	50			
20	218.1	202.98	120	25	50			
21	228.2	213.04	140	25	55			
22	238.3	233.11	140	25	55			
23	248.3	233.17	140	25	55			
24	258.4	243.23	140	25	55			
25	268.5	253.33	140	25	55			

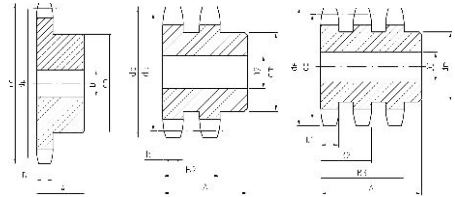

PITCH 1" 1/4X3/4"

For Chain
Acc. to DIN 8188 ASA 100
ISO/R 606

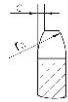

SPROCKETS	mm
Tooth radius r _s	33.5
Radius width C	4
Tooth width B ₁	18.0
Tooth width b ₁	17.7
Tooth width B ₂	53.5
Tooth width B ₃	89.2

CHAIN	mm
Pitch	31.75
Internal width	19.05
Roller	19.05
Material: C45	

PLATEWHEELS			S	D	T
Z	d _e	d _p	D ₁	D ₂	D ₃
8	98.1	82.96	16		
9	108.0	92.84	16		
10	117.9	102.74	16		
11	127.8	112.68	16		
12	137.8	122.68	20		
13	147.8	132.65	20		
14	157.8	142.68	20		
15	167.9	152.72	20		
16	177.9	162.75	20		
17	187.9	172.78	20		
18	198.0	182.85	20		
19	208.1	192.91	20	25	
20	218.1	202.98	20		
21	228.2	213.04	25		
22	238.3	233.11	25		
23	248.3	233.17	25		
24	258.4	243.23	25		
25	268.5	253.33	25	25	
26	278.6	263.40	25		
27	288.6	273.40	25		
28	298.7	283.56	25		
29	308.8	293.65	25		
30	318.9	303.75	25	25	
31	329.0	313.85	25		
32	339.1	323.91	25		
33	349.2	334.01	25		
34	359.3	344.10	25		
35	369.4	354.20	25		
36	379.5	364.30	25		
37	389.5	374.39	25		
38	399.6	384.49	25	30	
39	409.7	394.59	25		
40	419.8	404.68	25		
45	470.3	455.17	30	30	
57	591.5	576.36	30	30	

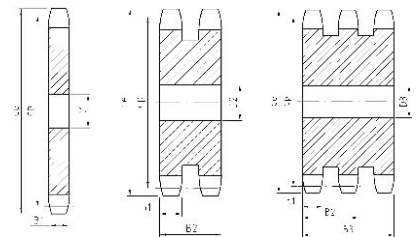

PITCH 1" 1/4X3/4"

For Chain
Acc. to DIN 8188 ASA 100
ISO/R 606

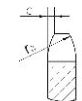

PLATEWHEELS	mm
Tooth radius r _s	33.5
Radius width C	4
Tooth width B ₁	18.0
Tooth width b ₁	17.7
Tooth width B ₂	53.5
Tooth width B ₃	89.2

CHAIN	mm
Pitch	31.75
Internal width	19.05
Roller	19.05



GOODWILL

ASA120 | ASA Sprockets & Platewheels

Sprockets
Platewheels

SPROCKETS			SIMPLEX			DUPLEX		
Z	d _e	d _p	d _m	D ₁	A	d _m	D ₂	A
8	119.04	99.55	58	20	45			
9	130.88	111.40	70	20	45			
10	142.77	123.29	80	20	45			
11	154.71	135.21	90	25	50			
12	166.69	147.22	102	25	50	102	25	100
13	178.68	159.18	114	25	50	114	25	100
14	190.70	171.22	128	25	50	128	25	100
15	202.73	183.26	140	25	50	140	25	100
PLATEWHEELS			SIMPLEX			DUPLEX		
Z	d _e	d _p		D ₁			D ₂	
16	214.77	195.29		25				
17	226.83	207.35		25			25	
18	238.89	219.41		25			25	
20	263.03	243.55		25			25	
22	287.20	267.72		25				
25	323.47	303.99		25			25	
30	383.97	364.49		30			30	
32	408.19	388.71		30				
38	480.85	461.37		30			30	
45	565.67	546.19		30			40	
57	711.10	691.62					40	

PITCH 1" 1/2X1"

For Chain **ASA 120**
Acc. to DIN 8188
ISO/R 606

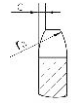

SPROCKETS & PLATEWHEELS mm

Tooth radius r _s	40.5
Radius width C	4.8
Tooth width B ₁	24.1
Tooth width b ₁	23.6
Tooth width B ₂	69.0
B ₃	114.5

CHAIN mm

Pitch	38.1
Internal width	25.4
Roller	22.22
Material: C45	

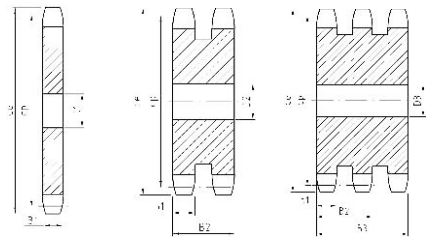
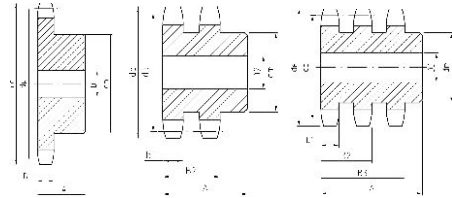

ALL toothings not mentioned any longer are available until sold out. Toothings and pitches of ASA profiles not included in this Catalog can be manufactured upon request.

Finished Bore Sprockets

For Roller Chains DIN8187-ISO/R606

ALL sprockets are finished with induction hardened teeth.

This treatment gives a longer lasting life to sprockets.

And with finished bore, keyway and 2 grub

Screws, this eliminates further

modification by customer

and can be fitted

immediately.



Bore-Keyway-Screws

D(H7)	B(H9)	T	M
10	4	D+1.8 (+0.1/0)	M3
11	4	D+1.8 (+0.1/0)	M3
12	4	D+1.8 (+0.1/0)	M3
14	5	D+2.3 (+0.1/0)	M4
16	5	D+2.3 (+0.1/0)	M4
18	6	D+2.8 (+0.1/0)	M5
19	6	D+2.8 (+0.1/0)	M5
20	6	D+2.8 (+0.1/0)	M5
22	6	D+2.8 (+0.1/0)	M5
24	8	D+3.3 (+0.2/0)	M6
25	8	D+3.3 (+0.2/0)	M6
28	8	D+3.3 (+0.2/0)	M6
30	8	D+3.3 (+0.2/0)	M6
32	10	D+3.3 (+0.2/0)	M8
35	10	D+3.3 (+0.2/0)	M8
38	10	D+3.3 (+0.2/0)	M8
40	12	D+3.3 (+0.2/0)	M10
42	12	D+3.3 (+0.2/0)	M10
45	14	D+3.8 (+0.2/0)	M12
48	14	D+3.8 (+0.2/0)	M12
50	14	D+3.8 (+0.2/0)	M12
60	18	D+4.4 (+0.2/0)	M12
65	18	D+4.4 (+0.2/0)	M12
70	20	D+4.9 (+0.2/0)	M12

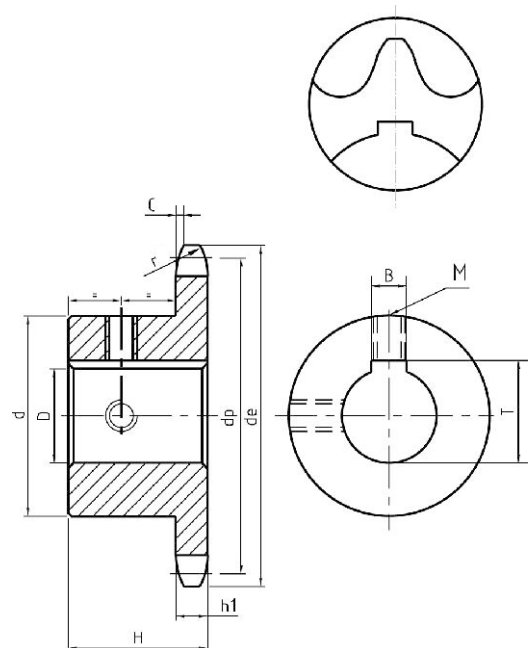



GOODWILL

Finished Bore Sprockets

3/8" X 7/32"

CHAIN:

Pitch	9.525
Internal width	5.72
Roller	6.35

ISO mm

SPROCKETS

Tooth radius r	10
Radius width C	1
Tooth width h ₁	5.3

06B-1 9.525 X 5.72mm

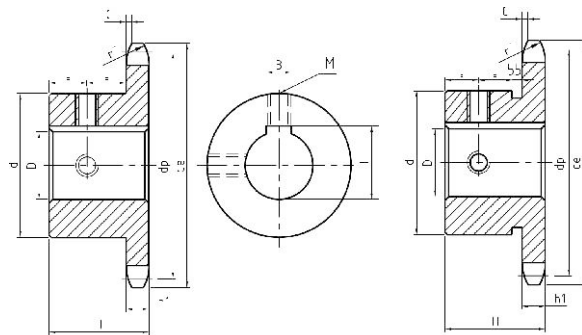

Type(*)

Material : C 45

Z	d _e	d _p	D	H	d
10	34	30.80	10	22	24
			11		26
			12		29
			14		29
11	37	33.8	10	25	24
			12		26
			14		29*
			16		31*
12	40	36.8	10	25	25
			12		26
			14		29
			16		31*
13	43	39.8	10	25	28
			12		28
			14		29
			16		31
14	46.3	42.8	12	25	31
			14		31
			16		35
			18		35
15	49.3	45.81	12	25	34
			14		34
			16		35
			18		35
16	52.3	48.82	12	28	37
			14		37
			16		37
			18		37

Z	d _e	d _p	D	H	d
16	52.3	48.82	22	16	37
			24		42
			25		42
			12		42
17	55.3	51.83	14	28	40
			16		40
			18		40
			19		40
18	58.3	54.85	20	28	43
			22		43
			24		43
			25		43
19	61.3	57.87	12	28	45
			14		45
			16		45
			18		45
20	64.3	60.89	12	28	46
			14		46
			16		46
			18		46

Z	d _e	d _p	D	H	d
20	64.3	60.89	24	28	46
			25		46
21	68	63.91	16	28	48
			18		48
			19		48
			20		48
22	71	66.93	22	28	50
			24		50
			25		50
			16		50
23	73.5	69.95	18	28	52
			19		52
			20		52
			22		52
24	77	72.97	24	28	54
			25		54
			16		54
			18		54
25	80	76	16	28	57
			18		57
			19		57
			20		57



GOODWILL

Finished Bore Sprockets

Finished Bore Sprockets

1/2" X 5/16"	
CHAIN:	ISO mm
Pitch	12.7
Internal width	7.75
Roller	8.51
SPROCKETS	
Tooth radius r	13
Radius width C	1.3
Tooth width h ₁	7.2

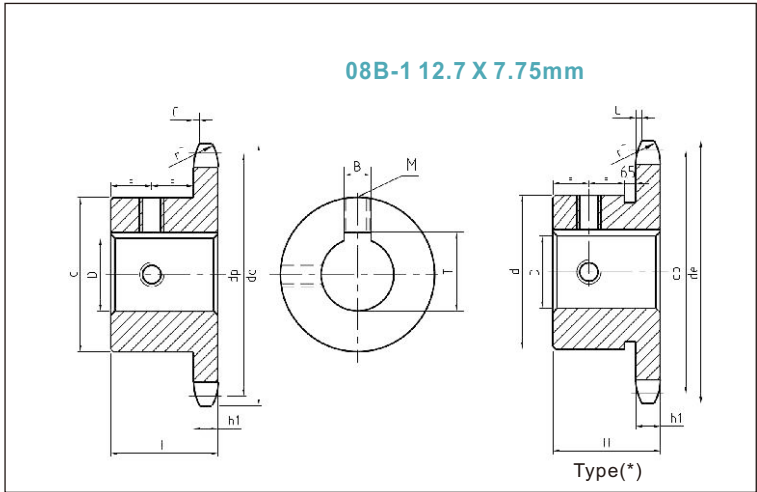

Material : C 45

Z	d _a	d _p	D	H	d
10	45.2	41.1	12	25	26
			14		29
			16		31
			18		33
11	48.7	45.07	12	25	29
			14		31
			16		34
			18		35
			19		35
			20		35
12	53	49.07	12	28	33
			14		35
			16		36
			18		38
			19		41*
			20		42*
			22		42*
			24		42*
13	57.4	53.06	12	28	37
			14		42
			16		45*
			18		45*
			19		45*
			20		45*
			22		45*
			24		45*
			25		45*
			28		45*
14	61.8	57.07	12	28	41
			14		45
			16		45
			18		45
			19		45
			20		45
			22		45
			24		45
			25		45
			28		45
			30		45
			32		45
15	65.5	61.09	12	28	45
			14		45
			16		45
			18		45

Z	d _a	d _p	D	H	d
15	65.5	61.09	18	28	45
			19		45
			20		45
			22		45
			24		45
			25		45
			28		45
			30		45
			32		45
			35		45
16	69.5	65.1	16	28	50
			18		50
			19		50
			20		50
			22		50
			24		50
			25		50
			28		50
			30		50
			32		50
17	73.6	69.11	16	28	52
			18		52
			19		52
			20		52
			22		52
			24		52
			25		52
			28		52
			30		52
			32		52
18	77.8	73.14	16	28	56
			18		56
			19		56
			20		56
			22		56
			24		56
			25		56
			28		56
			30		56
			32		56

Z	d _a	d _p	D	H	d
18	77.8	73.14	38	28	56
			16		56
			18		56
			19		56
			20		56
			22		56
			24		56
			25		56
			28		56
			30		56
19	81.7	77.16	24	28	60
			25		60
			28		60
			30		60
			32		60
			35		60
			38		60
			40		60
			42		60
			45		60
20	85.8	81.19	16	28	64
			18		64
			19		64
			20		64
			22		64
			24		64
			25		64
			28		64
			30		64
			32		64
21	89.7	85.22	24	28	68
			25		68
			28		68
			30		68
			32		68
			35		68
			38		68
			40		68
			42		68
			45		68
22	93.8	89.24	16	28	70
			18		70
			19		70
			20		70
			22		70
			24		70

Z	d _a	d _p	D	H	d
22	93.8	89.24	20	28	70
			22		70
			24		70
			25		70
			28		70
			30		70
			32		70
			35		70
			38		70
			40		70
23	98.2	93.27	25	28	70
			28		70
			30		70
			32		70
			35		70
			38		70
			40		70
			42		70
			45		70
			48		70
24	101.8	97.29	28	28	70
			30		70
			32		70
			35		70
			38		70
			40		70
			42		70
			45		70
			48		70
			50		70
25	105.8	101.33	19	28	70
			20		70
			22		70
			24		70
			25		70
			28		70
			30		70
			32		70
			35		70
			38		70



GOODWILL

Finished Bore Sprockets

5/8" X 3/8"

CHAIN:

Pitch
Internal width
Roller

ISO
mm

15.875
9.65
10.16

SPROCKETS

Tooth radius r
Radius width C
Tooth width h₁

16
1.6
9.1

10B-1 15.875 X 9.65mm

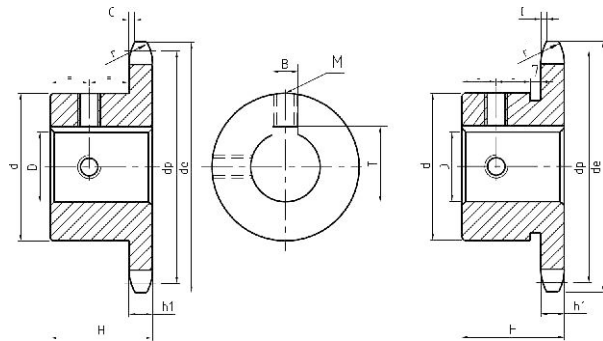

Type(*)

Material : C 45

Z	d _s	d _p	D	H	d
10	57.5	51.37	16	25	35
			19		
			20		
			24		
			42*		
11	63	56.34	16	30	37
			18		
			19		
			24		
			42		
12	68	61.34	20	30	42
			22		
			24		
			25		
			28		
13	73	66.32	16	30	47
			18		
			19		
			20		
			22		
14	78	71.34	24	30	52
			25		
			28		
			30		
			32		
15	83	76.36	19	30	57

Z	d _s	d _p	D	H	d
15	83	76.36	20	30	57
			22		
			24		
			25		
			28		
			30		
			32		
			35		
			19		
			20		
16	88	81.37	28	30	60
			30		
			32		
			35		
			38		
			19		
			20		
			22		
			24		
			25		
17	93	86.39	25	30	60
			28		
			30		
			32		
			35		
			38		
			19		
			20		
			22		
			24		
18	98.3	91.42	25	30	70
			28		
			30		
			32		
			35		
			38		
			40		
			42		
			19		
			20		
19	103.3	96.45	19	30	70
			20		

Z	d _s	d _p	D	H	d
19	103.3	96.45	22	30	70
			24		
			25		
			28		
			30		
			32		
			35		
			38		
			40		
			42		
20	108.4	101.49	19	30	75
			20		
			22		
			24		
			25		
			28		
			30		
			32		
			35		
			38		
21	113.4	106.52	28	30	75
			30		
			32		
			35		
			38		
			40		
			42		
			19		
			20		
			22		
22	118	111.55	20	30	80
			22		
			24		
			25		
			28		
			30		
			32		

Z	d _s	d _p	D	H	d
22	118	111.55	35	30	80
			38		
			40		
			42		
			19		
23	123.4	116.58	19	30	80
			20		
			22		
			24		
			25		
			28		
			30		
			32		
			35		
			38		
24	128.3	121.62	20	30	80
			22		
			24		
			25		
			28		
			30		
			32		
			35		
			38		
			40		
25	134	126.66	28	30	80
			30		
			32		
			35		
			38		
			40		
			42		



Finished Bore Sprockets

3/4" X 7/16"

CHAIN:

	ISO
	mm
Pitch	19.05
Internal width	11.68
Roller	12.07

SPROCKETS

Tooth radius r	19
Radius width C	2
Tooth width h ₁	11.1

12B-1 19.05 X 11.68mm

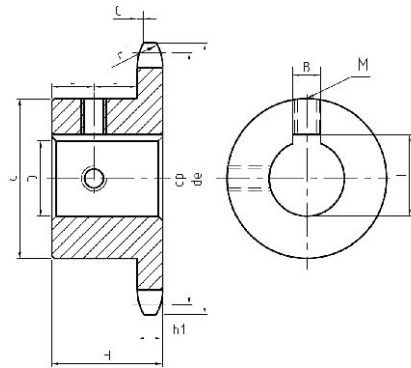

Material : C 45

Z	d _e	d _p	D	H	d
10	69	61.64	19	30	42
			20		
			24		
			25		
			28		
			30		
			32		
11	75	67.61	19	35	48
			20		
			24		
			25		
			28		
			30		
			32		
12	81.5	73.6	19	35	52
			20		
			22		
			24		
			25		
			28		
			30		
13	87.5	79.59	19	35	58
			20		
			22		
			24		
			25		
			28		
			30		
14	93.6	85.61	19	35	64
			20		
			22		
			24		
			25		
			28		
			30		

Z	d _e	d _p	D	H	d
14	93.6	85.61	32	35	64
			35		
			38		
			40		
			19		
			20		
			22		
15	99.8	91.63	24	35	70
			25		
			28		
			30		
			32		
			35		
			38		
16	105.5	97.65	19	35	75
			20		
			22		
			24		
			25		
			28		
			30		
17	115.5	103.67	25	35	80
			28		
			30		
			32		
			35		
			38		
			40		
18	118	109.71	25	35	80
			28		
			30		
			32		
			35		
			38		
			40		

Z	d _e	d _p	D	H	d
18	118	109.71	40	35	80
			42		
			25		
			28		
			30		
			32		
			35		
19	124.2	115.75	35	35	80
			38		
			40		
			42		
			45		
			48		
			50		
20	129.7	121.78	25	35	80
			28		
			30		
			32		
			35		
			38		
			40		
21	136	127.82	42	35	90
			45		
			48		
			50		
			25		
			28		
			30		
22	141.8	133.86	32	40	90
			35		
			38		
			40		
			42		
			45		
			48		

Z	d _e	d _p	D	H	d
22	141.8	133.86	38	40	90
			40		
			42		
			45		
			48		
			50		
			25		
23	149	139.9	40	40	90
			42		
			45		
			48		
			50		
			25		
			28		
24	153.9	145.94	35	40	90
			38		
			40		
			42		
			45		
			48		
			50		
25	160	152	25	40	90
			28		
			30		
			32		
			35		
			38		
			40		
			42		
			45		
			48		
			50		

Finished Bore Sprockets



GOODWILL

Finished Bore Sprockets

1" X17.02

CHAIN:

Pitch
Internal width
Roller

ISO
mm

25.4
17.02
15.88

SPROCKETS

Tooth radius r
Radius width C
Tooth width h₁

26
2.5
16.2

16B-1 25.4 X 17.02mm

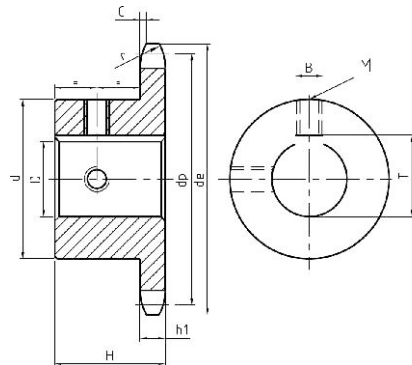

Material : C 45

Z	d _e	d _p	D	H	d
11	99.5	90.14	25	40	61
			28		
			30		
			32		
			35		
			38		
			40		
			42		
			65		
			67		
69					
12	109	98.14	25	40	69
			28		
			30		
			32		
			35		
			38		
			40		
			42		
			65		
			67		
69					
13	117	106.12	25	40	78
			28		
			30		
			32		
			35		
			38		
			40		
			42		
			45		
			48		
50					
82					
14	125	114.15	25	40	84
			28		
			30		
			32		
			35		
			38		
			40		
			42		
			45		
			48		
50					
84					
15	133	122.17	25	40	92
			28		

Z	d _e	d _p	D	H	d
15	133	122.17	30	40	92
			32		
			35		
			38		
			40		
			42		
			45		
			48		
			50		
			65		
67					
69					
16	141	130.2	25	45	100
			28		
			30		
			32		
			35		
			38		
			40		
			42		
			45		
			48		
50					
100					
17	149	138.22	25	45	100
			28		
			30		
			32		
			35		
			38		
			40		
			42		
			45		
			48		
50					
100					
18	157	146.28	25	45	100
			28		
			30		
			32		
			35		
			38		
			40		
			42		
			45		
			48		
50					
100					

Z	d _e	d _p	D	H	d
18	157	146.28	48	45	100
			50		
			25		
			28		
			30		
19	165.2	154.33	32	45	100
			35		
			38		
			40		
			42		
			45		
			48		
			50		
			65		
			67		
69					
20	173.2	162.38	25	45	100
			28		
			30		
			32		
			35		
			38		
			40		
			42		
			45		
			48		
50					
100					
21	181.2	170.43	25	45	110
			28		
			30		
			32		
			35		
			38		
			40		
			42		
			45		
			48		
50					
110					
22	189.3	178.48	25	45	110
			28		
			30		
			32		
			35		
			38		
			40		
			42		
			45		
			48		
50					
110					

Z	d _e	d _p	D	H	d
22	189.3	178.48	38	50	110
			40		
			42		
			45		
			48		
23	197.5	186.53	25	50	110
			28		
			30		
			32		
			35		
			38		
			40		
			42		
			45		
			48		
50					
110					
24	205.5	194.59	25	50	110
			28		
			30		
			32		
			35		
			38		
			40		
			42		
			45		
			48		
50					
110					
25	213.5	202.66	25	50	110
			28		
			30		
			32		
			35		
			38		
			40		
			42		
			45		
			48		
50					
110					



GOODWILL

Finished Bore Sprockets

1" 1/4X3/4"

CHAIN:	ISO
	mm
Pitch	31.75
Internal width	19.56
Roller	19.05

SPROCKETS

Tooth radius r	32
Radius width C	3.5
Tooth width h _t	18.5

20B-1 31.75 X 19.56mm

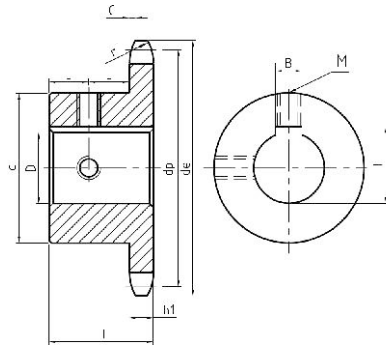

Finished Bore Sprockets

Material : C 45

Z	d _e	d _p	D	H	d	
09	108	92.84	25	40	63	
			30			
			32			
			35			
			38			
			45			
10	117.9	102.74	25	40	70	
			30			
			32			
			35			
			38			
			45			
11	127.8	112.68	25	45	77	
			28			
			30			
			32			
			35			
			38			
			40			
			42			
			45			
			50			82
			60			93
			12			137.8
28						
30						
32						
35						
38						
40						
42						
45						
50	93					
60	93					
13	147.8	132.65		25	45	
			28			
			31			
			31			

Z	d _e	d _p	D	H	d
13	147.8	132.65	32	45	98
			35		
			38		
			40		
			42		
			45		
			48		
			50		
			60		
			70		
14	157.8	142.68	32	45	108
			35		
			38		
			40		
			42		
			45		
			48		
			50		
			60		
			70		
15	167.9	152.72	32	45	118
			35		
			38		
			40		
			42		
			45		
			48		
			50		
			60		
			70		
16	177.9	162.75	38	50	120
			40		
			42		
			45		
			48		
			50		
			60		
			65		
			70		
			70		

Z	d _e	d _p	D	H	d
17	187.9	172.78	38	50	120
			40		
			42		
			45		
			48		
			50		
			60		
			65		
			70		
			70		
18	198	182.85	38	50	120
			40		
			42		
			45		
			48		
			50		
			60		
			65		
			70		
			70		
19	208.1	192.91	38	50	120
			40		
			42		
			45		
			48		
			50		
			60		
			65		
			70		
			70		
20	218.1	202.98	38	50	120
			40		
			42		
			45		
			48		
			50		
			60		
			65		
			70		
			70		

Taper Bore Sprockets

1" X17.02"

16B-1-2-3 25.4X17.2mm DIN 8187 ISO/R 606

CHAIN:	ISO mm
Pitch	25.4
Internal width	17.02
Roller	15.88

SPROCKETS	ISO mm
Tooth radius r	26
Radius width C	2.5
Tooth width h ₁	16.2
Tooth width L	16.2
Tooth width h ₂	47.7
Tooth width h ₃	79.6

Steel=C45
*Cast iron=G22

Z	de	dp	TS				TD				TT						
			D	H	for Bush	Type	D	H	for Bush	Type	D	H	for Bush	Type			
13	117.0	106.12	73	38	1615	1	-	-	-	-	-	-	-	-	-	-	-
15	133.0	122.17	76	38	1615	1	-	47.7	2012	3	-	79.6	2517	-	-	-	5
17	149.0	138.22	90	32	2012	1	-	47.7	2517	3	-	79.6	3030	-	-	-	5
19	165.2	154.33	108	45	2517	1	-	47.7	2517	3	-	79.6	3030	-	-	-	5
21	181.2	170.43	110	45	2517	1	140	51	3020	2	159	89	3535	-	-	-	4
23	197.5	186.53	110	45	2517	1	140	51	3020	2	175	89	3535	-	-	-	4
25	213.5	202.66	110	45	2517	1	140	51	3020	2	175	89	3535	-	-	-	4
27	229.6	218.79	110	45	2517	1	140	51	3020	2	175	89	3535	-	-	-	4
30	254.0	243.00	140	51	3020	1	140	76	3030	2	175	89	3535	-	-	-	4
38	320.7	307.59	140	51	3020	1	140	76	3030	2	175	89	3535	-	-	-	4
45	377.1	364.13	140	51	3020	6	140	76	3030	7	215	102	4040	-	-	-	8
*57	474.0	461.07	140	51	3020	6	175	89	3535	7	215	102	4040	-	-	-	8
*76	627.0	614.65	140	51	3020	6	175	89	3535	7	215	102	4040	-	-	-	8
*95	781.1	768.22	140	51	3020	6	215	102	4040	7	215	102	4040	-	-	-	8
*114	934.3	921.81	140	76	3020	6	215	102	4040	7	260	114	4045	-	-	-	8

1" 1/4X3/4"

20B-1-2-3 31.75X19.56mm DIN 8187 ISO/R 606

CHAIN:	ISO mm
Pitch	31.75
Internal width	19.56
Roller	19.05

SPROCKETS	ISO mm
Tooth radius r	32
Radius width C	3.5
Tooth width h ₁	18.5
Tooth width L	18.2
Tooth width h ₂	54.6
Tooth width h ₃	91

Steel=C45
*Cast iron=G22

Z	de	dp	TS			
			D	H	for Bush	Type
13	147.8	132.65	90	32	2012	1
15	167.9	152.72	108	45	2517	1
17	187.9	172.78	108	45	2517	1
19	208.1	192.91	108	45	2517	1
21	228.2	213.04	108	45	2517	1
23	248.3	233.17	108	45	2517	1
25	268.5	253.33	108	45	2517	1
27	288.6	273.40	150	51	3020	1
30	318.9	303.75	150	51	3020	1
38	399.6	384.49	160	51	3020	6
*45	470.3	455.17	160	51	3020	6
*57	591.5	576.36	160	51	3020	6
*76	783.5	768.32	160	51	3020	6



GOODWILL

Cast Iron Sprockets

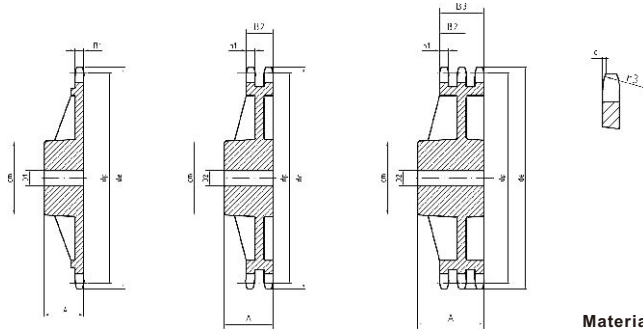

Material:GG22-GG25

Cast Iron Sprockets

3/8 " X7/32 " 06B-1-2-3 Acc.to DIN 8187 ISO/R 606

Z	d _o	d _p	SIMPLEX			DUPLEX			TRIPLEX		
			d _m	D ₁	A	d _m	D _z	A	d _m	D ₃	A
38	119.5	115.35	70	20	32	80	20	40	90	24	56
45	140.7	136.55	70	20	32	80	20	40	90	24	56
57	176.9	172.91	70	20	32	80	20	40	90	24	56
76	234.9	230.49	70	20	32	80	20	40	100	24	56
95	292.5	288.08	80	20	40	90	20	45	100	24	56
114	349.6	345.68	80	20	40	95	20	45	100	24	56
150	459.2	454.82	90	24	45	100	24	50	125	24	60

SPROCKETS		mm
Tooth radius r _s		10
Radius width C		1
Tooth width B ₁		5.3
Tooth width b ₁		5.2
Tooth width B ₂		15.4
Tooth width B ₃		25.6
CHAIN		mm
Pitch		9.525
Internal width		5.72
Roller		6.35

1/2 " X5/16 " 08B-1-2-3 Acc.to DIN 8187 ISO/R 606

Z	d _o	d _p	SIMPLEX			DUPLEX			TRIPLEX		
			d _m	D ₁	A	d _m	D _z	A	d _m	D ₃	A
38	158.6	153.80	70	20	40	90	24	50	100	24	60
45	188.0	182.07	70	20	40	90	24	50	100	24	60
57	236.4	230.54	70	20	40	90	24	50	100	24	60
76	313.3	307.33	80	24	40	100	24	56	100	24	60
95	390.1	384.11	80	24	45	100	24	56	120	24	67
114	466.9	460.90	80	24	45	100	24	63	120	24	67

SPROCKETS		mm
Tooth radius r _s		13
Radius width C		1.3
Tooth width B ₁		7.2
Tooth width b ₁		7
Tooth width B ₂		21
Tooth width B ₃		34.9
CHAIN		mm
Pitch		12.7
Internal width		7.75
Roller		8.51

5/8 " X3/8 " 10B-1-2-3 Acc.to DIN 8187 ISO/R 606

Z	d _o	d _p	SIMPLEX			DUPLEX			TRIPLEX		
			d _m	D ₁	A	d _m	D _z	A	d _m	D ₃	A
38	199.2	192.24	80	20	40	100	30	50	100	32	60
45	235.0	227.58	80	20	40	100	30	50	100	32	60
57	296.0	288.18	90	24	45	100	30	56	100	32	63
76	392.1	384.16	90	24	50	100	30	63	110	35	67
95	488.5	480.14	100	24	56	110	30	63	125	35	70
114	584.1	576.13	100	24	56	125	30	70	125	35	80

SPROCKETS		mm
Tooth radius r _s		16
Radius width C		1.6
Tooth width B ₁		9.1
Tooth width b ₁		9
Tooth width B ₂		25.5
Tooth width B ₃		42.1
CHAIN		mm
Pitch		15.875
Internal width		9.65
Roller		10.16

3/4 " X7/16 " 12B-1-2-3 Acc.to DIN 8187 ISO/R 606

Z	d _o	d _p	SIMPLEX			DUPLEX			TRIPLEX		
			d _m	D ₁	A	d _m	D _z	A	d _m	D ₃	A
38	239.0	230.69	100	24	56	110	30	63	140	30	70
45	282.5	273.10	100	24	56	110	30	63	140	30	70
57	354.0	345.81	100	30	56	120	30	63	140	40	70
76	469.9	460.99	100	30	56	135	30	63	160	40	75
95	585.1	576.17	100	30	65	135	30	70	170	40	82
114	700.6	691.36	100	30	65	135	30	70	170	50	82

SPROCKETS		mm
Tooth radius r _s		19
Radius width C		2
Tooth width B ₁		11.1
Tooth width b ₁		10.8
Tooth width B ₂		30.3
Tooth width B ₃		49.8
CHAIN		mm
Pitch		19.05
Internal width		11.68
Roller		12.07



GOODWILL

Cast Iron Sprockets

For Roller Chinas DIN8187-ISO/R606

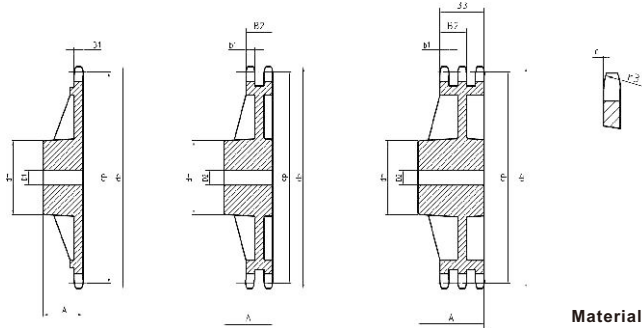

Material:GG22-GG25

1" X17.02mm 06B-1-2-3 Acc.to DIN 8187 ISO/R 606

Z	d _e	d _p	SIMPLEX			DUPLEX			TRIPLEX		
			d _m	D ₁	A	d _m	D ₁₂	A	d _m	D ₃	A
30	254.0	243.00	110	30	65	125	40	75	145	40	90
38	320.0	307.59	110	30	65	140	40	75	160	45	100
45	377.0	364.13	125	30	70	150	40	75	160	45	100
57	474.0	461.08	125	35	70	170	40	90	165	45	100
76	627.0	614.65	140	35	80	175	40	95	200	45	110
95	781.0	768.22	140	40	80	175	45	95	200	50	110
114	933.0	921.81	140	40	80	175	45	95	200	50	115

SPROCKETS

	mm
Tooth radius r _s	26
Radius width C	2.5
Tooth width B ₁	16.2
Tooth width b ₁	15.8
Tooth width B ₂	47.7
Tooth width B ₃	79.6

CHAIN:

	mm
Pitch	25.4
Internal width	17.02
Roller	15.88

1" 1/4X3/4" 20B-1-2-3 Acc.to DIN 8187 ISO/R 606

Z	d _e	d _p	SIMPLEX			DUPLEX			TRIPLEX		
			d _m	D ₁	A	d _m	D ₁₂	A	d _m	D ₃	A
30	318.9	303.75	115	35	70	130	40	80	160	50	100
38	399.6	384.49	125	35	70	140	45	90	180	56	110
45	470.3	455.17	125	35	70	140	45	90	180	56	110
57	591.5	576.36	135	40	80	160	50	100	180	60	125
76	783.5	768.32	140	40	90	180	50	100	200	60	140

SPROCKETS

	mm
Tooth radius r _s	32
Radius width C	3.5
Tooth width B ₁	18.5
Tooth width b ₁	18.2
Tooth width B ₂	54.6
Tooth width B ₃	91

CHAIN:

	mm
Pitch	31.75
Internal width	19.56
Roller	19.05

1" 1/2X1" 24B-1-2-3 Acc.to DIN 8187 ISO/R 606

Z	d _e	d _p	SIMPLEX			DUPLEX			TRIPLEX		
			d _m	D ₁	A	d _m	D ₁₂	A	d _m	D ₃	A
30	379.5	364.50	130	40	85	160	40	95	180	60	150
38	476.2	461.39	140	45	90	180	45	100	200	60	150
45	561.2	546.20	140	45	90	180	45	100	200	60	150
57	706.5	691.63	160	45	100	200	55	110	200	70	150
76	936.9	921.98	170	45	100	220	55	120	250	70	150

SPROCKETS

	mm
Tooth radius r _s	38
Radius width C	4
Tooth width B ₁	24.1
Tooth width b ₁	23.6
Tooth width B ₂	72
Tooth width B ₃	120.3

CHAIN:

	mm
Pitch	38.1
Internal width	25.4
Roller	25.4



GOODWILL

Platewheels For Conveyor Chain

Z	d _e	d _p	S			Z	d _e	d _p	S		
			D ₁						D ₁		
12	85.7	77.28	14								
14	98.3	89.88	14								
15	104.6	96.18	14								
16	110.9	102.52	16								
17	117.2	108.82	16								
19	129.9	121.52	16								
20	136.2	127.84	16								
21	142.6	134.18	20								
23	155.3	146.88	20								
26	174.3	165.92	20								
27	180.7	172.27	20								
35	231.5	223.12	20								
38	250.6	242.18	25								
39	256.9	248.54	25								
40	263.3	254.92	25								

PLATEWHEELS 20X16mm

For chains Acc.to DIN 8164

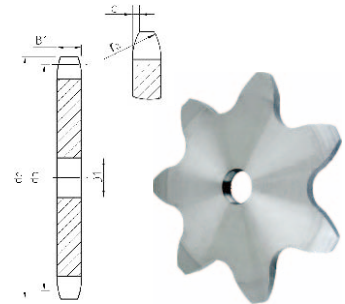

PLATEWHEELS mm

Tooth radius r ₃	20
Radius width C	1.7
Tooth width B ₁	14.5

CHAIN: mm

Pitch	20
Internal width	16
Roller	12

Z	d _e	d _p	S			Z	d _e	d _p	S		
			D ₁						D ₁		
11	117.4	106.48	20								
12	126.9	115.91	20								
13	137.3	125.36	20								
15	156.2	144.29	20								
17	175.2	163.27	20								
21	213.2	201.29	25								
22	222.8	210.80	25								
23	232.3	220.32	25								
27	270.4	258.41	25								
30	299.0	287.00	25								
38	375.2	363.27	30								

PLATEWHEELS 30X17.02mm

For chains Acc.to DIN 8164

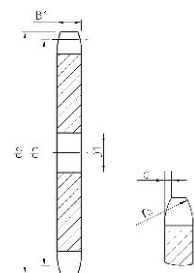

PLATEWHEELS mm

Tooth radius r ₃	27
Radius width C	2.2
Tooth width B ₁	15.8

CHAIN: mm

Pitch	30
Internal width	17.02
Roller	15.88



GOODWILL

Platewheels For Conveyor Chain

Z	d _e	d _p	S			Z	d _e	d _p	S		
			D ₁						D ₁		
12	85.7	77.28	14								
14	98.3	89.88	14								
15	104.6	96.18	14								
16	110.9	102.52	16								
17	117.2	108.82	16								
19	129.9	121.52	16								
20	136.2	127.84	16								
21	142.6	134.18	20								
23	155.3	146.88	20								
26	174.3	165.92	20								
27	180.7	172.27	20								
35	231.5	223.12	20								
38	250.6	242.18	25								
39	256.9	248.54	25								
40	263.3	254.92	25								

Z	d _e	d _p	S			Z	d _e	d _p	S		
			D ₁						D ₁		
11	117.4	106.48	20								
12	126.9	115.91	20								
13	137.3	125.36	20								
15	156.2	144.29	20								
17	175.2	163.27	20								
21	213.2	201.29	25								
22	222.8	210.80	25								
23	232.3	220.32	25								
27	270.4	258.41	25								
30	299.0	287.00	25								
38	375.2	363.27	30								

PLATEWHEELS 20X16mm

For chains Acc.to DIN 8164

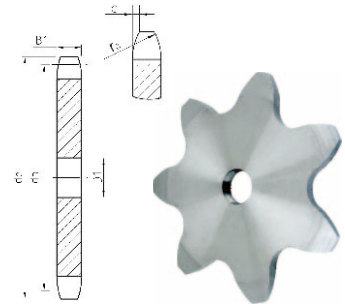

PLATEWHEELS mm

Tooth radius r ₃	20
Radius width C	1.7
Tooth width B ₁	14.5

CHAIN: mm

Pitch	20
Internal width	16
Roller	12

PLATEWHEELS 30X17.02mm

For chains Acc.to DIN 8164

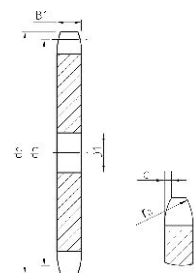

PLATEWHEELS mm

Tooth radius r ₃	27
Radius width C	2.2
Tooth width B ₁	15.8

CHAIN: mm

Pitch	30
Internal width	17.02
Roller	15.88



GOODWILL

Platewheels For Conveyor Chain

Platewheels

Z	Roller 25			Roller 28			Roller 31		
	d _e	d _p	D ₁	d _e	d _p	D ₁	d _e	d _p	D ₁
6	115.0	100.00	20				116.2	100.00	20
7	132.7	115.24	20				133.8	115.24	20
8	148.1	130.60	25	150.2	130.60	25	152.3	130.60	25
9	163.7	146.20	25				167.9	146.20	25
10	179.3	161.85	25	181.4	161.85	25	183.5	161.85	25
11	195.0	177.50	25				199.2	177.50	25
12	211.0	193.20	25				212.0	193.20	25
13	226.4	208.95	30				230.6	208.95	30
14	242.2	224.70	30	244.3	244.70	30	246.4	224.70	30
15	257.9	240.45	30	260.0	240.45	30	262.1	240.45	30
16	273.8	256.30	30				278.0	256.30	30
17	289.5	272.05	30				293.7	272.05	30
18	305.4	287.95	30	307.5	287.95	30	309.6	287.95	30
19	321.3	303.80	30				325.5	303.80	30
20	337.1	319.60	30				341.3	319.60	30
21	352.9	335.45	30				357.1	335.45	30
22				370.9	351.35	30	373.0	351.35	30
23							388.9	367.20	30
24	400.0	383.05	30	402.6	383.05	30	404.7	383.05	30
25	416.4	398.95	30				419.7	398.95	30
26	432.3	414.80	30				436.5	414.80	30
27	448.2	430.70	30				452.4	430.70	30
28	464.0	446.55	30				468.2	446.55	30
29	480.0	462.50	30						
30	495.8	478.35	30						
32							431.8	510.10	30
35							579.5	557.80	30
38	622.9	605.45	30				622.0	605.45	30

Z	Roller 25			Roller 31					
	d _e	d _p	D ₁	d _e	d _p	D ₁			
8	213.4	195.98	30	217.6	195.98	30			
9	236.8	219.30	30	241.0	219.30	30			
10	260.2	242.77	30	264.4	242.77	30			
11	283.7	266.25	30	287.9	266.25	30			
12	307.3	289.80	30	311.5	289.80	30			
13	330.9	313.42	30	334.1	313.42	30			
14				358.7	337.05	30			
15	378.1	360.67	30	382.3	360.67	30			
16	401.9	384.45	30	406.1	384.45	30			
17				429.7	408.07	30			
20	496.9	479.40	30						
21				524.8	503.17	30			
25	615.9	598.42	30	620.1	598.42	30			

PLATE WHEELS P 50

R 25-28-31



CHAIN: mm

Pitch 50
Internal width 11.5
Roller 25
Tooth width B₁ 10.5

CHAIN: mm

Pitch 50
Internal width 15
Roller 28
Tooth width B₁ 13.5

CHAIN: mm

Pitch 50
Internal width 15
Roller 31
Tooth width B₁ 13.5

PLATEWHEELS P75

R 25-31



CHAIN: mm

Pitch 75
Internal width 11.5
Roller 25
Tooth width B₁ 10.5

CHAIN: mm

Pitch 75
Internal width 15
Roller 31
Tooth width B₁ 13.5



GOODWILL

Platewheels For Conveyor Chain

Z	Roller 25			Roller 31			Roller 40		
	d _e	d _p	D ₁	d _e	d _p	D ₁	d _e	d _p	D ₁
8	278.7	261.31	30	282.9	261.31	30	283.0	261.31	30
9				314.1	292.40	30	314.0	292.40	30
10	341.2	323.61	30	345.4	323.61	30	345.0	323.61	30
11	372.5	345.95	30	376.7	354.95	30	378.0	354.95	30
12	403.9	386.40	30	408.1	386.40	30	409.0	386.40	30
13				439.6	417.90	30			
14				471.1	449.40	30	473.0	449.40	30
15				502.6	480.90	30			
16				534.3	512.60	30	536.0	512.60	30
17				565.8	544.10	30			
18				597.6	575.90	30			
19							663.0	639.20	30
20									

PLATEWHEEL1 P.100

R_o 25-31-40

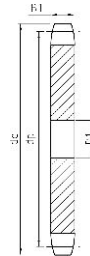

CHAIN: mm

Pitch	100
Internal width	11.5
Roller	25
Tooth width B ₁	10.5

CHAIN: mm

Pitch	100
Internal width	15
Roller	31
Tooth width B ₁	13.5

CHAIN: mm

Pitch	100
Internal width	22
Roller	40
Tooth width B ₁	20

TABLE TOP WHEELS

Z	d _e	D ₁	L
13	78.98	15	43.5
15	93.67	15	43.5
17	105.47	20	43.5
19	117.34	20	43.5
21	129.26	20	43.5
23	141.22	20	43.5
25	153.21	20	43.5
27	165.20	20	43.5
29	177.24	20	43.5
31	189.28	20	43.5

TABLE TOP WHEELS
For chains Acc.to DIN 8153





GOODWILL

Idler Sprockets With Ball Bearing

Z	Pitch	d_e	d_p	A	D_1	F	B	H	h
23	8 X 3	62.15	58.75	2.8	16	40	12	18.3	7
21	3/8" X 7/32"	68.0	63.90	5.3	16	40	12	18.3	7
18	1/2" X 1/8"	78.9	73.14	3	16	40	12	18.3	7
18	1/2" X 3/16"	78.9	73.13	4.5	16	40	12	18.3	7
16	1/2" X 5/16"	69.5	65.10	7.2	16	40	12	18.3	7.2
18	1/2" X 5/16"	77.8	73.14	7.2	16	40	12	18.3	7.2
14	5/8" X 3/8"	78.0	71.34	9.1	16	40	12	18.3	9.1
15	5/8" X 3/8"	83.0	76.36	9.1	16	40	12	18.3	9.1
17	5/8" X 3/8"	93.0	86.39	9.1	16	40	12	18.3	9.1
13	3/4" X 7/16"	87.5	79.59	11.1	16	40	12	18.3	11.1
15	3/4" X 7/16"	99.8	91.63	11.1	16	40	12	18.3	11.1
12	1" X 17.02	109.0	98.14	16.2	20	47	14	17.7	16.2
13	1" 1/4 X 3/4"	147.8	132.65	18.5	25	52	15	21.0	18.5

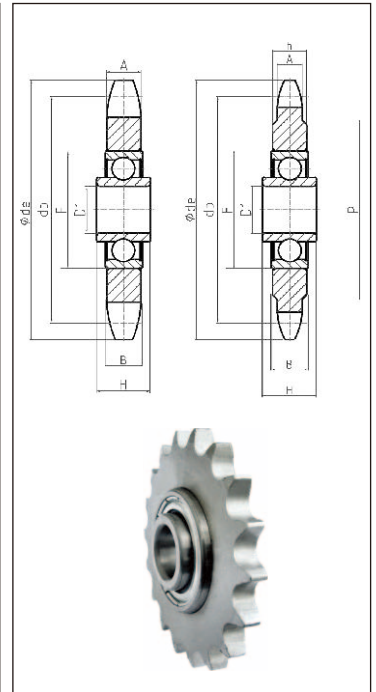

DISASSEMBLING HUBS FOR PLATEWHEELS

Nr.	d_e	d_i	d_M^{hg}	A	D_f	B_f	H_f
30	55	45	30	20.0	4.2	4	3.0
40	70	58	40	25.0	5.2	5	5.2
50	80	67	50	32.0	6.2	7	7.0
60	90	76	60	38.5	6.2	7	8.7
70	110	94	70	45.5	8.2	8	10.5
80	130	107	80	55.0	8.2	12	15.0
100	170	140	100	73.0	10.2	17	23.0
140	220	182	140	83.0	12.2	20	23.0
160	245	205	160	93.0	16.5	25	25.0

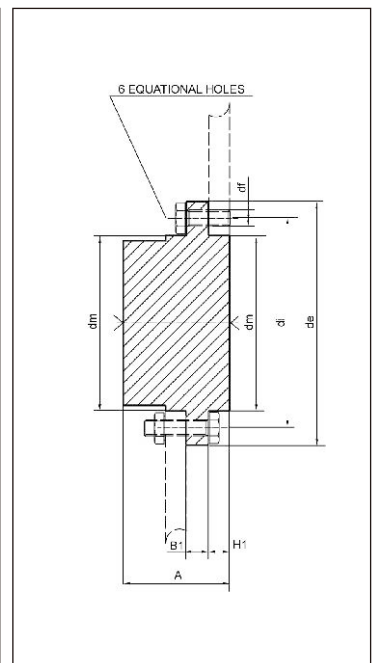

Duplex Platewheels For Two Single Roller Chains



For Roller Chains DIN8187-ISO/R606

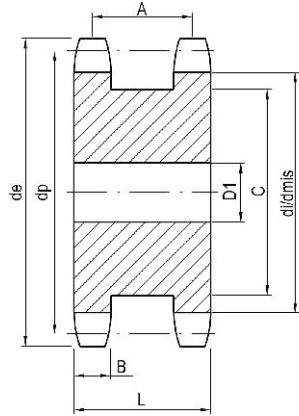

Type	Z	d _e	d _p	d _i	d _{mis}	D	A	B h14	C _{max}	L
3/8" X 7/32" R6.35	13	43	39.80	33.45	33.16	10	20.3	5.3	28	25.5
	15	49.3	45.81	39.46	39.21	10	20.3	5.3	34	25.5
	17	55.3	51.84	45.49	45.27	12	20.3	5.3	40	25.5
	19	61.3	57.87	51.52	51.32	12	20.3	5.3	46	25.5
	21	68	63.91	57.56	57.38	15	20.3	5.3	52	25.5
	23	73.5	69.95	63.60	63.44	15	20.3	5.3	59	25.5
06B-1	25	80	76.00	69.65	69.50	15	20.3	5.3	65	25.5
1/2" X 5/16" R8.51	13	57.4	53.07	44.56	44.17	10	24.8	7.2	37	32
	15	65.5	61.08	52.57	52.24	10	24.8	7.2	45	32
	17	73.6	69.12	60.61	60.31	12	24.8	7.2	53	32
	19	81.7	77.16	68.65	68.39	12	24.8	7.2	62	32
	21	89.7	85.21	76.71	76.46	15	24.8	7.2	70	32
	23	98.2	93.27	84.76	84.54	15	24.8	7.2	78	32
08B-1	25	105.8	101.33	92.82	92.62	15	24.8	7.2	86	32
5/8" X 3/8" R10.16	13	73	66.33	56.17	55.69	15	27.9	9.1	48	37
	15	83	76.35	66.19	65.78	15	27.9	9.1	58	37
	17	93	86.39	76.23	75.87	15	27.9	9.1	68	37
	19	103.3	96.45	86.29	85.96	19	27.9	9.1	79	37
	21	113.4	106.51	96.35	96.06	19	27.9	9.1	89	37
	23	123.4	116.59	106.43	106.15	19	27.9	9.1	99	37
10B-1	25	134	126.66	116.50	116.25	19	27.9	9.1	109	37
3/4" X 7/16" R12.07	13	87.5	79.60	67.53	66.95	20	33.9	11.1	59	45
	15	99.8	91.63	79.56	79.05	20	33.9	11.1	71	45
	17	111.5	103.67	91.60	91.18	20	33.9	11.1	83	45
	19	124.2	115.74	103.67	103.27	20	33.9	11.1	95	45
	21	136	127.82	115.75	115.39	24	33.9	11.1	107	45
	23	149	139.90	127.83	127.51	24	33.9	11.1	119	45
12B-1	25	160	151.99	139.92	139.62	24	33.9	11.1	131	45
1" X 17.02 R15.88	13	117	106.14	90.26	89.48	24	47.8	16.2	78	64
	15	133	122.17	106.29	105.62	24	47.8	16.2	95	64
	17	149	138.23	122.35	121.76	24	47.8	16.2	111	64
	19	165.2	154.32	138.44	137.91	24	47.8	16.2	127	64
	21	181.2	170.42	154.54	154.06	24	47.8	16.2	143	64
16B-1										